



## Power Macintosh 8100/ WS 8150

---

Power Macintosh 8100/80 and 8100/80AV, Power  
Macintosh 8100/100 and 8100/100AV, Power  
Macintosh 8100/110, Workgroup Server 8150,  
Workgroup Server 8150/110





## Basics

---

Power Macintosh 8100/WS 8150





## Power Macintosh System Overview

PowerPC microprocessors are a family of processors built on reduced instruction-set computing (RISC) technology. RISC processors streamline the internal workings of computers. Whereas traditional (complex instruction-set computing, or CISC) processors contain a wide variety of instructions to handle many different tasks, RISC processors contain only those instructions that are used most often. When a complex instruction is needed, a RISC processor builds it from a combination of basic instructions.

RISC processors are designed to execute these basic instructions extremely quickly. The performance gains achieved by speeding up the most-used instructions more than compensate for the time spent creating less-used instructions.





Previously, RISC technology had been used only in high-end workstations and commercial database servers. With the introduction of Macintosh PowerPC computers, Apple succeeded in bringing RISC technology to personal computing.

## Key Points

Three key points to remember about a PowerPC processor-based Macintosh system: It's a Macintosh; it's compatible; it offers tremendous performance.

Apple's PowerPC computers feature the same user interface as their 680x0-based predecessors. Users can mix RISC-based and 680x0-based Macintosh systems on the same network and exchange files and disks between them. In addition, users can run both 680x0 and native PowerPC applications on the same Power Macintosh system simultaneously.





Compatibility is not limited just to applications. INITs, CDEVs, drivers, and other Macintosh utility software also work on PowerPC processor-based Macintosh systems. So do AppleTalk devices (such as printers), SCSI devices (such as hard drives and scanners), ADB devices (such as mice, trackballs, and keyboards), and other Macintosh cards and peripherals.

The primary operating system for PowerPC processor-based Macintosh computers is System 7. The operating system has been optimized for the highest performance on the PowerPC processor. This optimization of System 7 benefits applications written for 680x0 systems as well as those developed specifically for PowerPC processor-based systems.

And while PowerPC-based Macintosh systems running native applications offer two to four times the performance





of the fastest 68040- and 80486-based personal computers, the real promise of PowerPC technology is that it enables Apple and other developers to deliver new software capabilities on Macintosh systems that were previously available only on high-end workstations.

## Troubleshooting Tips

When troubleshooting Power Macintosh systems, keep in mind the following:

- 1 If a Power Macintosh system does not power up, you should first attempt to reset the logic board. Instructions are provided in the Additional Procedures chapter.
- 2 With Power Macintosh computers, you must install noncomposite RAM SIMMs only, and the RAM SIMMs must be installed in like pairs (that is, the same size and speed). Additional troubleshooting information is





provided in the Symptom Charts section of the Troubleshooting chapter under the “System” topic heading.

- 3 If a Power Macintosh system has bad RAM SIMMs installed, you will not hear death chimes. Instead, a dialog box will appear alerting you to the fact that a bad RAM SIMM has been detected. Additional troubleshooting information is provided in the Symptom Charts section of the Troubleshooting chapter under the “System” topic heading.
- 4 If the system hangs shortly after installing a new NuBus card, contact the vendor to verify that the card is compatible with the Power Macintosh system or to see if there is a software upgrade available. If the NuBus card is an Apple manufactured product, refer to the Service Tech Info Library for more information.





- 5 The Power Macintosh AV systems use the same logic board as the non-AV versions. The only difference is that the AV versions have the Power Macintosh AV Card installed in the PDS slot.

The Power Macintosh 7100/66 and 8100/80 systems **must** have a video card installed in the PDS slot. The Power Macintosh 7100/66 system uses the Power Macintosh 2 MB Video Card and the Power Macintosh 8100/80 system uses the Power Macintosh 4 MB Video Card. A missing card can result in a system that won't boot or a system that crashes.







## HDI-45 Pinouts

This section includes an illustration of the HDI-45 connector and a table containing the pinout descriptions.

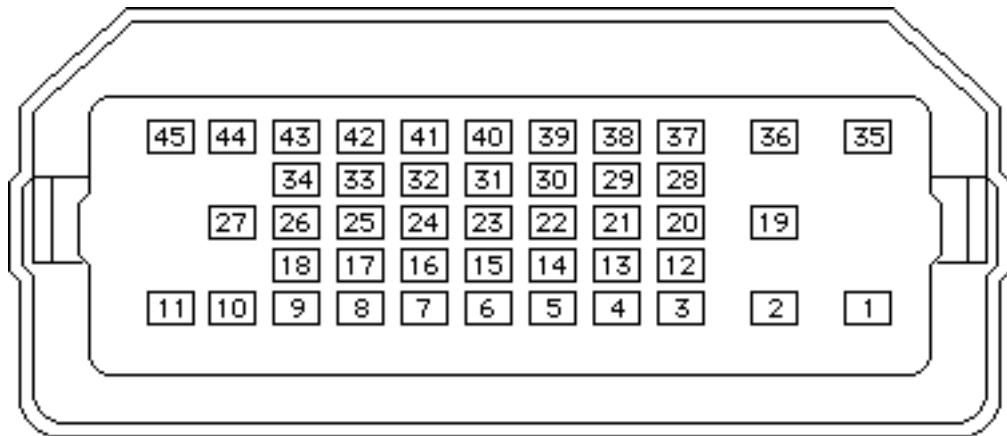

**Figure: HDI-45 Connector on the Logic Board**



**Table: HDI-45 Pinouts**

<b>Pin</b>	<b>Description</b>
1	Analog audio ground
2	Audio input shield
3	Left channel audio input
4	Right channel audio input
5	Left channel audio output
6	Right channel audio output
7	Reserved
8	Monitor ID sense line 1
9	Monitor ID sense line 2
10	Green ground (shield)





Pin	Description
11	Green video output (75 $\Omega$ )
12	Video input power ground
13	Power for camera +5 V
14	Reserved
15	Reserved
16	Reserved
17	Reserved
18	Monitor ID sense line 3
19	S-video input shield
20	S-video input luminance (Y)
21	S-video input chroma (C)





Pin	Description
22	Reserved
23	Reserved
24	Reserved
25	Reserved
26	Red ground (shield)
27	Red video output (75 $\Omega$ )
28	I <sup>2</sup> C data signal
29	I <sup>2</sup> C clock signal
30	Reserved
31	Monitor ID
32	Monitor ID





<b>Pin</b>	<b>Description</b>
33	Vertical sync signal
34	Composite sync signal
35	ADB power +5 V
36	ADB ground
37	ADB data
38	Keyboard switch
39	Reserved
40	Reserved
41	Monitor ID
42	Horizontal sync signal
43	Video sync ground





<b>Pin</b>	<b>Description</b>
44	Blue ground (shield)
45	Blue video output (75 $\Omega$ )





## Rear Panel Connectors

The figure on the following page shows a Power Macintosh 8100 computer with a 4 MB Video Card installed. The AV version of the Power Macintosh 8100 would have a Power Macintosh AV Card installed instead of the 4 MB Video Card. In addition to a DB-15 connector, the AV Card includes an S-Video Input and an S-Video Output port.



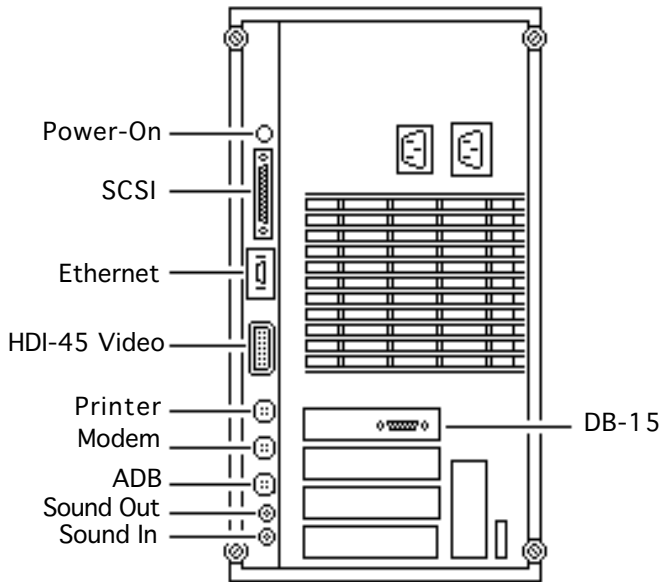

**Power Macintosh 8100 Rear Panel**







## Logic Board Connectors

The figure on the following page shows a Power Macintosh 8100/80 logic board.

**Caution:** It is important to note that the Power Macintosh 8100/100 and 8100/110 Series logic boards have a thermoelectrical cooling device that attaches directly to the microprocessor's heatsink. You can identify this cooling device by the black and red wires that run to the right of the heatsink and plug into the logic board via a keyed connector. This device is not a serviceable item. Do **not** unplug this device or you may damage the logic board.



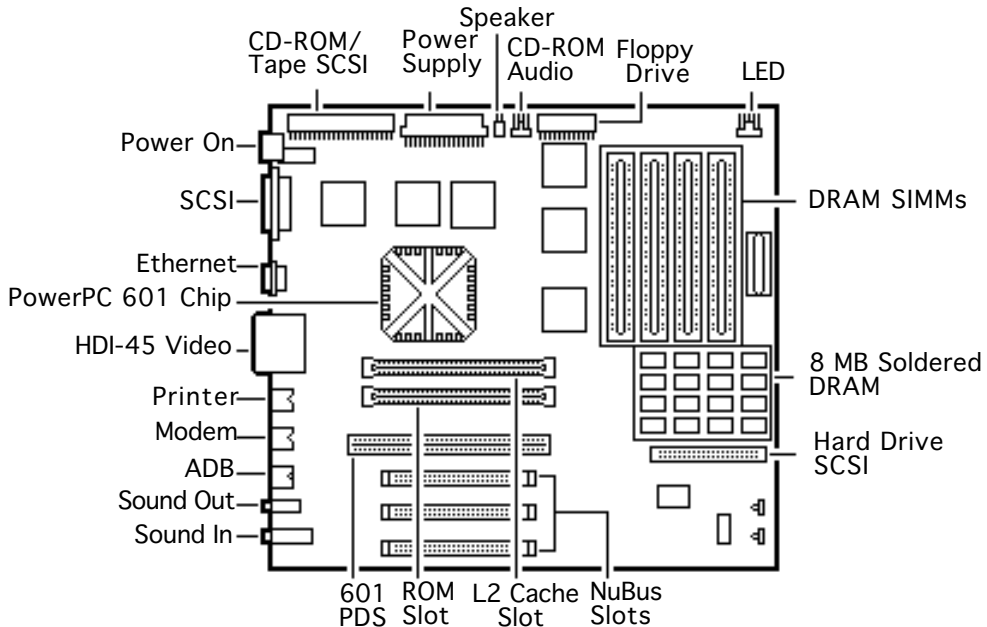



## Apple RAID Software

Apple RAID (Redundant Array of Independent Disks) software protects data from loss during a disk failure and enhances the speed of data storage and retrieval. It is available for all Power Macintosh Workgroup servers.

Data protection is achieved through disk mirroring, a data storage scheme in which identical data is stored on two different disks. Apple RAID can also be configured for disk striping, a data storage scheme in which successive units of data are transferred to several disks at one time.

If you plan to install the Apple RAID software on an existing Power Macintosh Workgroup Server, or if you are reinitializing an existing Apple RAID drive, keep in the mind the following:





- If you wish to use your server's startup disk for Apple RAID, do not install the Apple RAID program on your startup disk until you have initialized and set up new volumes on that disk. Before you initialize the startup disk, back up all valuable data.
- You must reinitialize all disks on which you will use Apple RAID volumes. Initializing with Apple RAID removes all data, so be sure to back up your disks first.
- Apple HD SC Setup does not recognize Apple RAID volumes. If you want to remove or resize volumes on Apple RAID disks, use the Apple RAID program.
- The Apple RAID CD contains the facilities to reinstall your system software. However, if you have made any customizations to your system files, such as adding extension files, control panels, or preference files, then





back up your system files now. Back them up in such a way that you can restore your system files separately from the nonsystem files on your disk. You will later restore your system files using the backup copy rather than the System Installer on the RAID CD, so that you preserve your system customizations.





## Specifications

---

Power Macintosh 8100/WS 8150





## Processor

### CPU

Built-in MMU and FPU

32K of on-chip cache memory

80, 100 or 110 MHz PowerPC 601 RISC microprocessor

#### **8100/80 & 8150**

Requires system software version 7.1.2 or later

#### **8100/100, 8100/110 & 8150/110**

Requires system software version 7.5 or later

**Note:** To run System 7.5 on these systems, you need enabler version 1.1.1 at a minimum. This version of the system software requires Finder version 7.1.5. You can verify the Finder version installed by using the "Get Info" command. Refer to the Tech Info Library for more information.





# Memory

## RAM

**8100/80, 8100/100 &  
8150**

8 MB RAM soldered on logic board, expandable to 264 MB via 8 SIMM sockets on logic board (using pairs of same size, 80 ns or faster, 72-pin noncomposite SIMMs); Optional 16 MB configuration has two 4 MB SIMMs installed

**8100/110 & 8150/110**

16 MB RAM standard (8 MB soldered on logic board and two 4 MB SIMMs), expandable to 264 MB via 8 SIMM sockets on logic board (using pairs of same size, 80 ns or faster, 72-pin noncomposite SIMMs)

**Note:** SIMMs must be installed in pairs of the same size. Install noncomposite SIMMS only.







## VRAM

**8100/80, 8100/100,  
8100/110, 8150 &  
8150/110**

2 MB of VRAM on video card, expandable to 4 MB using 512K  
VRAM SIMMs

**8100/80AV & 8100/  
100AV**

2 MB of VRAM on Macintosh AV card, including support for NTSC  
or PAL monitors

**8150 & 8150/110**

None

## ROM

4 MB installed on ROM SIMM

## Cache

32K on-chip cache; 256K level 2 cache SIMM

## Clock/Calendar

CMOS custom chip with long-life lithium battery





## Disk Storage

### Hard Drive

<b>8100/80</b>	500 MB or 1 GB hard drive
<b>8150</b>	500 MB, 1 GB, or 2 GB hard drive
<b>8100/100</b>	700 MB or 1 GB hard drive
<b>8100/110</b>	2 GB hard drive
<b>8150/110</b>	1 GB hard drive

### Floppy Drive

1.4 MB Apple SuperDrive Manual Insert





**CD-ROM Drive**

Internal AppleCD 300 Plus CD-ROM drive optional on some models and standard on other models

**8150/110**

AppleCD 600 CD-ROM drive standard





## I/O Interfaces

### **SCSI**

One SCSI port; DB-25 connector

Supports maximum of six external devices (five with CD-ROM drive)

### **Serial**

Two RS-232/RS-422 LocalTalk/GeoPort serial ports; mini DIN-9 connectors (backward compatible with mini DIN-8 connectors)

### **Apple Desktop Bus**

One Apple Desktop Bus (ADB) port; mini-Din-4 connector  
Maximum power draw 500 mA; maximum of three devices total

### **Ethernet**

One Ethernet port; AAUI-15 connector



**Expansion Slot**

One processor-direct slot (PDS); 182-pin connector

**NuBus**

Three slots support long or short expansion cards; 96-pin Euro-DIN connectors

**Sound**

16-bit stereo in and out

Sample rates of 48, 44.1, 24, and 22.05 kHz

Input/output line level: 1 V peak-to-peak

Input/output signal-to-noise ratio (SNR): 82 dB with no audible discrete tones

Bandwidth: 20 Hz–20 kHz ( $\pm 2$  dB) at 44.100 kHz sample rate

THD+N (total harmonic distortion plus noise): less than 0.05%, measured 20Hz–20kHz with a 1-V<sub>rms</sub> sine wave input



**Video**

One HDI-45 DRAM-based video port on logic board supports direct connection to Apple AudioVision monitors and with optional HDI-45 to DB-15 adapter supports 12-in., 13-in., 14-in., 15-in. portrait, 16-in., and 17-in. monitors

**8100/80, 8100/100,  
8100/110**

Come with a Power Macintosh 4 MB Video Card with one DB-15 VRAM-based video port that supports 12-in., 13-in., 14-in., 15-in. portrait, 16-in., 17-in., 20-in., and 21-in. monitors

**8100/80AV & 8100/  
100AV**

Come with a Power Macintosh AV Card\* with: one DB-15 VRAM-based video on the card that supports 12-in., 13-in., 14-in., 15-in. portrait, 16-in., 17-in., 20-in., and 21-in. monitors; one S-video/composite input port; and one S-video composite output port

\*Only one monitor can be attached to the card at one time (that is, either through the DB-15 port or the S-video port).





## Digital-Audio Video

**8100/80AV & 8100/  
100AV**

Support for DAV connector standard





## I/O Devices

### **Keyboard**

Standard, extended, or adjustable keyboard

Keyboard draws 25–80 mA, depending on model of keyboard

### **Mouse**

ADB Mouse II; Draws up to 10 mA

### **Microphone**

**8100/80, 8150 & 8150/  
110**

Optional Apple PlainTalk microphone; unidirectional and optimized for use with speech recognition

**8100/80AV, 8100/100,  
8100/100AV & 8100/  
110**

Apple PlainTalk microphone standard







## Video Display

### Video Support

System must have the Power Macintosh 4 MB Video Card, Power Macintosh AV Card, or PDS terminator board installed.

These systems support monochrome, color, VGA, and SVGA formats on the HDI-45 logic board connector, including:

- Macintosh 12" Monochrome Display (640 x 480)
- Macintosh 12" RGB Display (512 x 384)
- AppleColor High-Res RGB 14" Monitor (640 x 480)
- Apple AudioVision 14 Display (640 x 480)
- Macintosh Color Display (640 x 480)
- Macintosh 15" Portrait Display (640 x 870)
- Macintosh 16" Color Display (832 x 624)





## Video Support (cont'd)

All Power Macintosh 8100 series computers support the following monitors via the DB-15 connector on their respective video cards:

- Macintosh 19" Color Display (1024 x 768)
- Apple Multiple Scan 20 Display (1280 x 1024)
- Macintosh 21" Color Display (1152 x 870)

In addition, the AV versions support the following monitors via the DB-15 connector on the Power Macintosh AV Card:

- NTSC (512 x 384 and 640 x 480)
- PAL (640 x 480 and 768 x 576)





## Electrical

<b>A/C Line Input Voltage</b>	100–240 VAC; RMS single phase, automatically configured
<b>Input Line Frequency</b>	50–60 Hz, single phase
<b>Input Power</b>	298 W maximum continuous, 453 W peak input (not including monitor power)
<b>Power Supply DC Output</b>	200 W continuous output





## Physical

### **Dimensions**

Height: 14.25 in. (360 mm)

Width: 7.75 in. (196 mm)

Depth: 16 in. (396 mm)

### **Weight**

25.3 lb. (11.5 kg); weight varies depending on internal devices installed





## Environmental

**Operating  
Temperature**

50-104° F (10° to 40° C)

**Storage  
Temperature**

-40 to 116.6° F (-40 to 47° C)

**Relative Humidity**

5-90% noncondensing

**Altitude**

0-3048 m (0-10,000 ft.)





## Troubleshooting

Power Macintosh 8100/WS 8150





## General

The Symptom Charts included in this chapter will help you diagnose specific symptoms related to your product. Because cures are listed on the charts in the order of most likely solution, try the first cure first. Verify whether or not the product continues to exhibit the symptom. If the symptom persists, try the next cure. (Note: If you have replaced a module, reinstall the original module before you proceed to the next cure.)

If you are not sure what the problem is, or if the Symptom Charts do not resolve the problem, refer to the Flowchart for the product family.

For additional assistance, contact Apple Technical Support.





# Symptom Charts

## Power Supply

System does not  
power up

- 1 Reset logic board. (Refer to Additional Procedures.)
- 2 Reseat ROM SIMM and cache SIMM.
- 3 Replace power supply.
- 4 Replace logic board.







## Error Chords

One-part error  
chord sounds during  
startup sequence

- 1 Disconnect SCSI data cable from hard drive and reboot system. If startup sequence is normal, initialize hard drive. If error chord still sounds, replace hard drive.
- 2 Disconnect floppy drive cable from floppy drive and reboot system. If startup sequence is normal, replace floppy drive.
- 3 Replace logic board. Retain customer's SIMMs.





## System

Does not power on;  
screen is black, fan is  
not running, and LED  
is not lit

- 1 Check power cables.
- 2 Plug monitor directly into wall socket, and verify that monitor has power.
- 3 Reset logic board. (Refer to Additional Procedures.)
- 4 Reseat ROM SIMM and cache SIMM.
- 5 Replace power cord.
- 6 Replace power supply.
- 7 Replace logic board. Retain customer's SIMMs.

Clicking, chirping,  
or thumping

- 1 Replace power supply.
- 2 Replace logic board. Retain customer's SIMMs.
- 3 Replace floppy drive cable.
- 4 Replace floppy drive.





## System (Continued)

System shuts down intermittently

- 1 Make sure air vents are clear. Thermal protection circuitry may shut down system. After 30 to 40 minutes, system should be OK.
- 2 Replace power cord.
- 3 Check battery. Refer to “Battery Verification” in Additional Procedures.
- 4 Replace power supply.
- 5 Replace logic board. Retain customer’s SIMMs.





## System (Continued)

System  
intermittently  
crashes or hangs

- 1 Verify system software is version 7.1.2 or later.
- 2 Verify SIMMs are installed in pairs of same size/speed and are noncomposite.
- 3 Verify software is known-good.
- 4 Verify software is Power Macintosh compatible (contact developer).
- 5 Verify PDS slot has video card installed.
- 6 Clear parameter RAM. Hold down <Command> <Option> <P> <R> during startup but before “Welcome to Macintosh” appears.
- 7 Replace SIMMs.
- 8 Replace cache SIMM.
- 9 Replace logic board. Retain SIMMs.
- 10 Replace power supply.





## System (Continued)

During startup, following message is displayed, “This startup disk will not work on this Macintoshmodel.”

- 1 Verify that startup disk is good.
- 2 Verify that LED cable is securely attached to logic board.
- 3 Reinstall system software.
- 4 Replace LED cable.
- 5 Replace logic board. Retain customer’s SIMMs.





## Video

Screen is black, audio and drive operate, fan is running, and LED is lit

- 1 Adjust brightness on monitor.
- 2 Replace video cable.
- 3 Try using known-good RAM SIMMs.
- 4 Replace video card.
- 5 Clear parameter RAM. Hold down <Command> <Option> <P> <R> during startup but before “Welcome to Macintosh” appears.
- 6 Replace SIMMs.
- 7 Replace monitor. Refer to appropriate monitor manual to troubleshoot defective monitor.
- 8 Replace logic board. Retain customer’s SIMMs.
- 9 Replace power supply.





## Video (Continued)

Screen is black, audio and drive do not operate, but fan is running and LED is lit

- 1 Replace video cable.
- 2 Replace video card.
- 3 Replace SIMMs.
- 4 Replace logic board. Retain customer's SIMMs.
- 5 Replace power supply.

Partial or whole screen is bright and audio is present, but no video information is visible

- 1 Replace video cable.
- 2 Replace video card.
- 3 Clear parameter RAM. Hold down <Command> <Option> <P> <R> during startup but before "Welcome to Macintosh" appears.
- 4 Replace monitor. Refer to appropriate monitor manual to troubleshoot defective monitor.
- 5 Replace logic board. Retain customer's SIMMs.





## Video (Continued)

Multiple Scan  
monitor attached to  
Power Macintosh  
8100/80AV displays  
ghosting or video  
smearing

- 1 Replace Power Macintosh AV Card.







## Floppy Drive

Internal floppy drive does not operate

- 1 Replace disk with known-good floppy disk.
- 2 Replace floppy drive cable.
- 3 Replace floppy drive.
- 4 Replace logic board. Retain customer's SIMMs.
- 5 Replace power supply.

During system startup, disk ejects; display shows icon with blinking "X"

- 1 Replace disk with known-good system disk.
- 2 Clear parameter RAM. Hold down <Command> <Option> <P> <R> during startup but before "Welcome to Macintosh" appears.
- 3 Replace floppy drive cable.
- 4 Replace floppy drive.
- 5 Replace logic board. Retain customer's SIMMs.





## Floppy Drive (Continued)

Does not eject disk	<ol style="list-style-type: none"><li data-bbox="443 205 1415 288">1 Switch off computer. Hold mouse button down while you switch computer on.</li><li data-bbox="443 298 951 332">2 Replace floppy drive cable.</li><li data-bbox="443 342 856 377">3 Replace floppy drive.</li><li data-bbox="443 387 1268 430">4 Replace logic board. Retain customer's SIMMs.</li></ol>
Attempts to eject disk, but doesn't	<ol style="list-style-type: none"><li data-bbox="443 487 910 522">1 Push disk completely in.</li><li data-bbox="443 532 1395 615">2 Reseat floppy drive bezel and drive so bezel slot aligns correctly with drive.</li><li data-bbox="443 625 843 659">3 Eject disk manually.</li><li data-bbox="443 670 856 713">4 Replace floppy drive.</li></ol>
Internal floppy drive runs continuously	<ol style="list-style-type: none"><li data-bbox="443 772 1199 807">1 Replace disk with known-good floppy disk.</li><li data-bbox="443 817 951 851">2 Replace floppy drive cable.</li><li data-bbox="443 861 856 896">3 Replace floppy drive.</li><li data-bbox="443 906 1268 948">4 Replace logic board. Retain customer's SIMMs.</li></ol>





## **Floppy Drive (Continued)**

MS-DOS drive does not recognize a disk formatted on a 1.4 MB drive

- 1 To read and write files with either MS-DOS or 1.4 MB drive, format all disks with MS-DOS drive first.





## Hard Drive

Single internal hard drive does not operate; drive doesn't spin

- 1 Check the SCSI and hard drive power cable connections.
- 2 Replace hard drive power cable.
- 3 Replace hard drive. (Note: If replacing an Apple WS 8150 RAID drive, you must reinstall the RAID software on the drive. See "RAID Information" in Basics.)
- 4 Replace power supply.

No internal SCSI drives operate

- 1 Verify there are no duplicate SCSI device addresses.
- 2 Replace SCSI data cable.
- 3 Replace power supply.
- 4 Replace logic board. Retain customer's SIMMs.





## Hard Drive (Continued)

Drive does not appear on the desktop

- 1 Verify there are no duplicate SCSI device addresses.
- 2 Update the SCSI device driver using Apple HD SC Setup. Run Disk First Aid to verify the condition of the drive's directory structure.
- 3 Replace the SCSI hard drive cable.
- 4 If drive is not initialized, use HD SC Setup to initialize. (Note: Use Apple RAID to initialize RAID drives for the WS 8150 drives.)
- 5 Replace with known-good hard drive. (Note: If replacing an Apple WS 8150 RAID drive, you must reinstall the RAID software on the drive. See "RAID Information" in Basics.)
- 6 If the hard drive still doesn't work, switch back to the original hard drive and replace the logic board.





## Hard Drive (Continued)

Works with internal or external SCSI devices but not with both

- 1 Verify there are no duplicate SCSI device addresses.
- 2 Replace terminator on external SCSI device.
- 3 Verify that SCSI device at end of internal SCSI data cable is only device terminated.
- 4 Refer to appropriate manual to troubleshoot defective external device.





## Peripherals

Cursor does not move

- 1 Replace external SCSI cables.
- 2 Verify that there is only one terminator on external devices.
- 3 Check mouse connection.
- 4 Inspect inside of mouse for buildup of dirt or other contaminants. Clean mouse if necessary.
- 5 If mouse was connected to keyboard, connect mouse to computer ADB port instead. If mouse works, replace keyboard.
- 6 If mouse does not work in any ADB port on computer, replace mouse.
- 7 Replace logic board. Retain customer's SIMMs.





## Peripherals (Continued)

Cursor moves, but clicking mouse button has no effect

- 1 Replace mouse.
- 2 Replace logic board. Retain customer's SIMMs.

Double-click doesn't open application, disk, or server

- 1 Remove duplicate system folders.
- 2 Clear parameter RAM. Hold down <Command> <Option> <P> <R> during startup but before "Welcome to Macintosh" appears.
- 3 If mouse was connected to keyboard, connect mouse to computer ADB port instead. If mouse works, replace keyboard.
- 4 If mouse does not work in any ADB port on computer, replace mouse.
- 5 Replace logic board. Retain customer's SIMMs.







## Peripherals (Continued)

No response to any key on keyboard

- 1 Check keyboard connection to ADB port.
- 2 Replace keyboard cable.
- 3 Replace keyboard.
- 4 Replace logic board. Retain customer's SIMMs.

Known-good serial printer does not work

- 1 Verify you have correct version of system software (see Processor topic in Specifications chapter).
- 2 Verify that Chooser is set correctly.
- 3 Replace printer interface cable.
- 4 Replace logic board. Retain customer's SIMMs.

Known-good network printer does not print

- 1 Verify you have correct version of system software (see "Processor" topic in Specifications chapter).
- 2 Verify that Chooser is set correctly.
- 3 Replace logic board. Retain customer's SIMMs.





## Miscellaneous

No sound from speaker

- 1 Verify that volume setting in Control Panel is 1 or above.
- 2 Replace speaker.
- 3 Replace logic board. Retain customer's SIMMs.

About This Macintosh reports more memory than is installed

- 1 Verify that RAM SIMMs are installed in matching pairs (same size and speed).
- 2 Replace RAM SIMMs.

About This Macintosh reports less memory than is installed

- 1 Verify that RAM SIMMs are installed in matching pairs (same size and speed).
- 2 Replace RAM SIMMs.





## CD-ROM Drive

CD-ROM drive does not accept compact disc

- 1 Exchange disc.
- 2 Replace CD-ROM drive mechanism.

Macintosh does not display CD-ROM drive icon

- 1 Verify that CD-ROM software is installed.
- 2 Replace CD-ROM drive mechanism.
- 3 Replace SCSI data cable.

Computer with 600i CD-ROM drive makes stuttering sounds when playing CD+ or CD-R formatted discs or CD-ROM disc won't mount

Replace CD-ROM drive.





Take Apart

---

Power Macintosh 8100/WS 8150



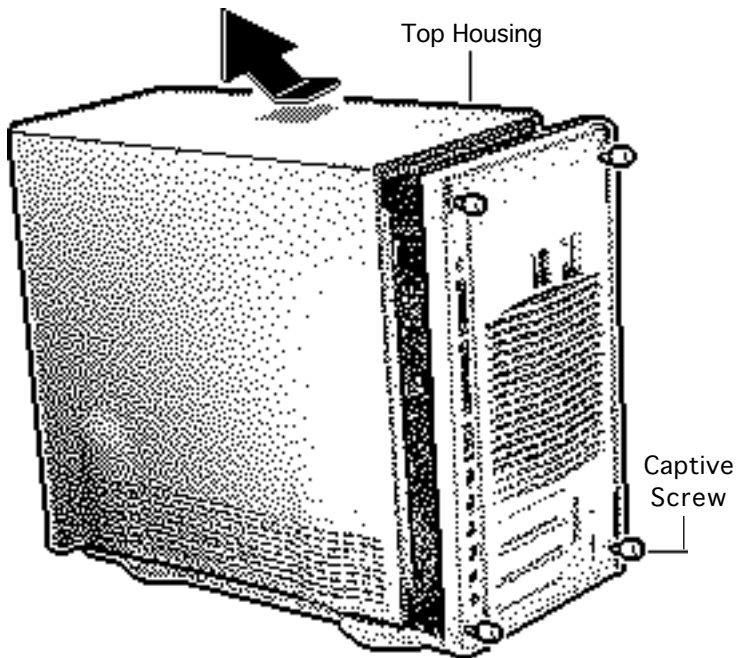

## Top Housing

No preliminary steps are required before you begin this procedure.

- 1 Loosen the four captive screws on the rear panel.
- 2 **Caution:** Be careful that you don't deform the metal dome-shaped shield inside the top housing.

Slide the top housing forward about 1/2 inch and lift the top housing.





## Floppy Drive

Before you begin, remove the following:

- Top housing
- CD-ROM drive

**Caution:** To prevent ESD damage, wear a grounding wriststrap. Review the ESD precautions in Bulletins/ Safety.

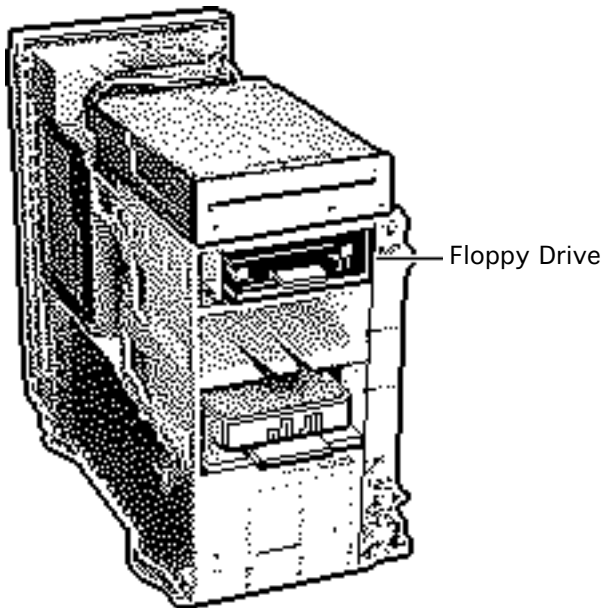

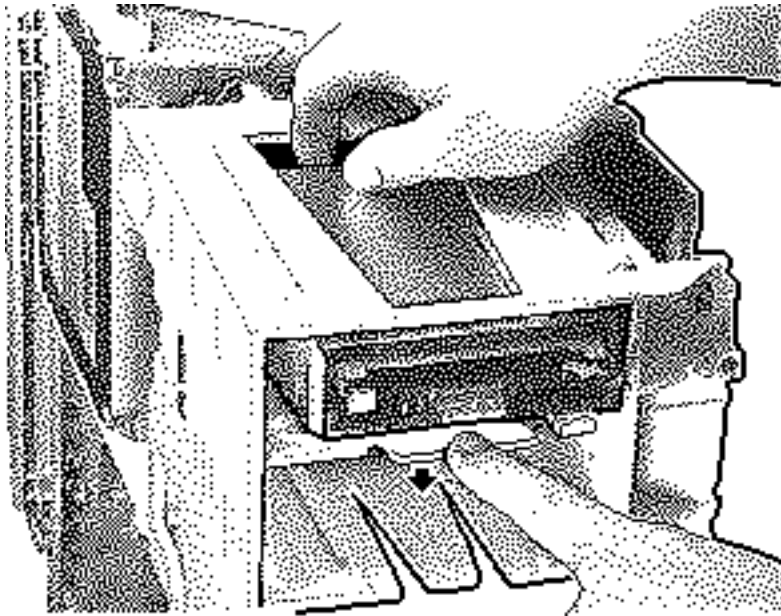

- 1 Press down the retaining clip securing the floppy drive and slide the floppy drive forward about 2 inches.
- 2 Disconnect the floppy drive cable from the floppy drive.
- 3 Remove the floppy drive from the chassis.
- 4 Remove the drive carrier from the drive.





## Hard Drive

Before you begin, remove the top housing.

**Caution:** To prevent ESD damage, wear a grounding wriststrap. Review the ESD precautions in Bulletins/ Safety.

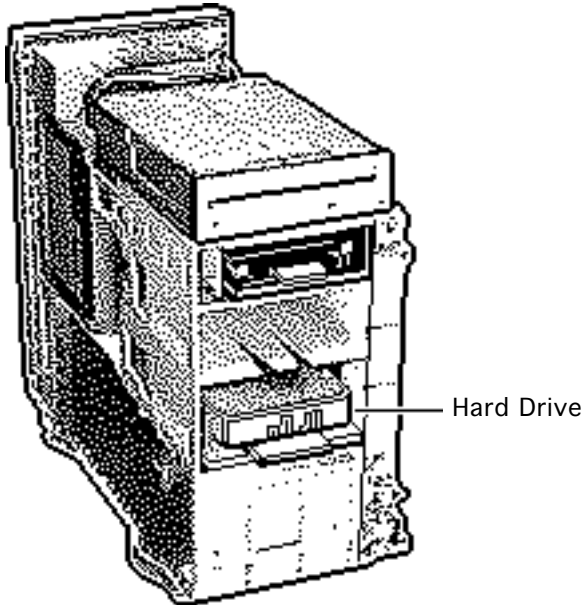



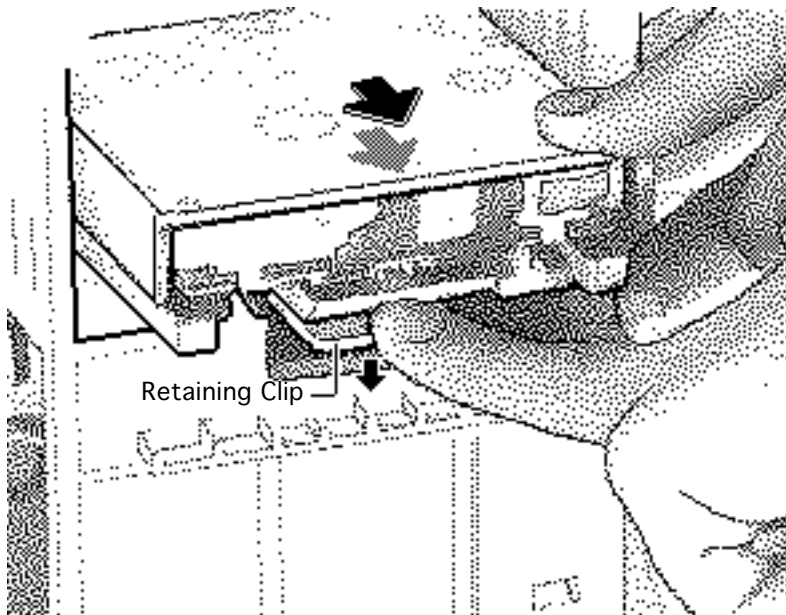

- 1 Disconnect the SCSI data cable and power cable from the back of the hard drive.

**Note:** There are two internal SCSI connectors on the logic board (see “Logic Board Connectors” in Basics for an illustration). In the standard configuration, the SCSI connector at the top of the logic board is used for the CD-ROM/Tape drives, and the SCSI connector near the bottom of the logic board (beneath the DRAM and



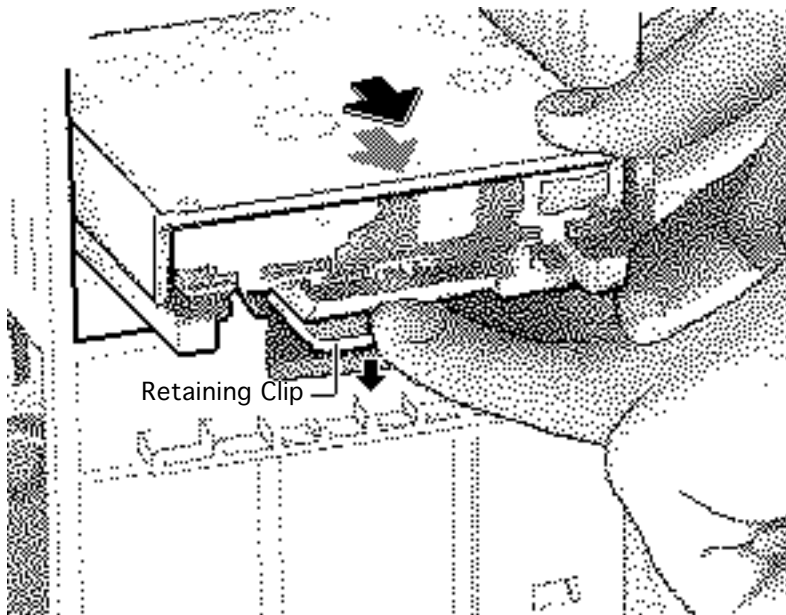

above the reset/interrupt switch) is used for the internal hard drive.

- 2 Press down the retaining clip securing the hard drive and slide the hard drive out.

**Replacement Note:** For information on removing the hard drive from its carrier and returning drives, cables, and carriers to Apple, refer to Additional Procedures in the Hard Drives manual.





## CD-ROM Drive

Before you begin, remove the top housing.

**Caution:** To prevent ESD damage, wear a grounding wriststrap. Review the ESD precautions in Bulletins/ Safety.

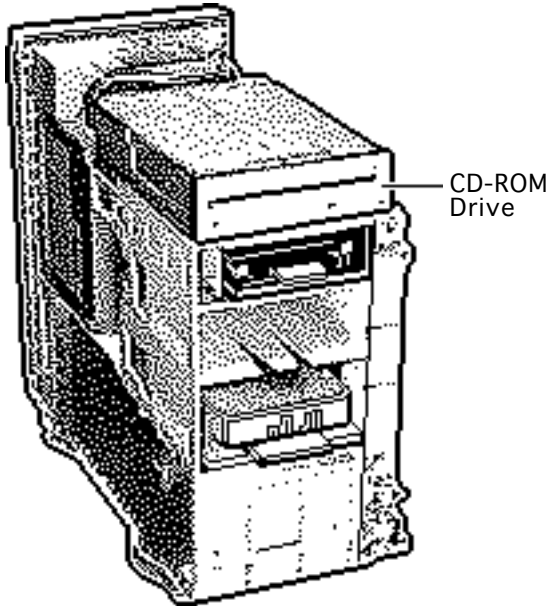

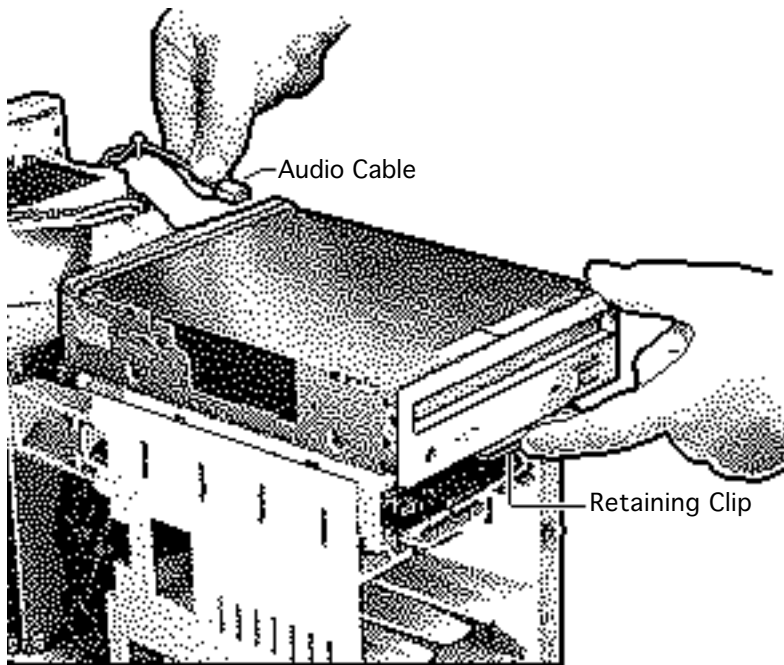

- 1 Disconnect the SCSI data cable, audio cable, and power cable from the back of the CD-ROM drive.

**Note:** There are two internal SCSI connectors on the logic board (see “Logic Board Connectors” in Basics for an illustration). In the standard configuration, the SCSI connector at the top of the logic board is used for the CD-ROM/Tape drives, and the SCSI connector near the bottom of the logic board (directly beneath the DRAM



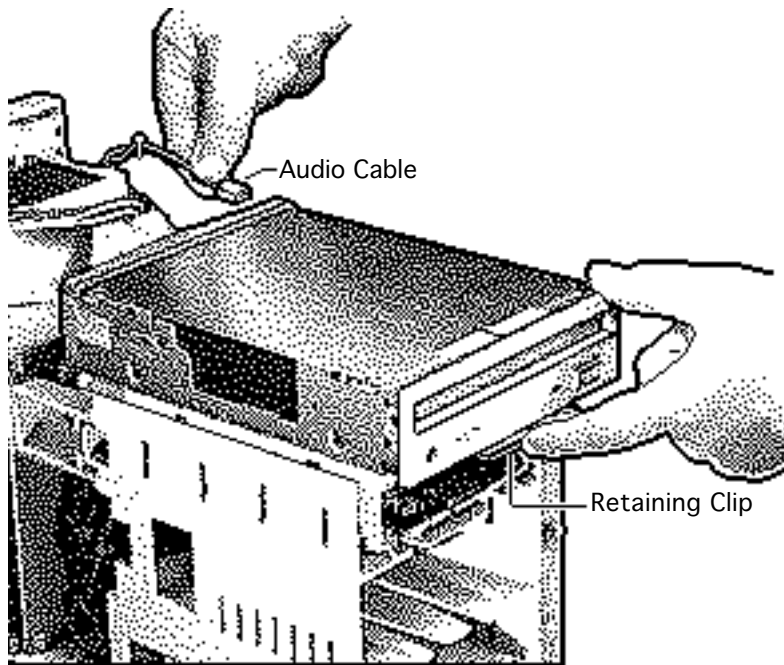

and above the reset/ interrupt switch) is used for the internal hard drive.

- 2 Pull up on the retaining clip securing the CD-ROM drive and slide the CD-ROM drive out.

**Replacement Note:** Be sure to remove the CD-ROM drive from the carrier prior to returning the drive to Apple.





## Tape Drive

Before you begin, remove the top housing.

**Caution:** To prevent ESD damage, wear a grounding wriststrap. Review the ESD precautions in Bulletins/ Safety.

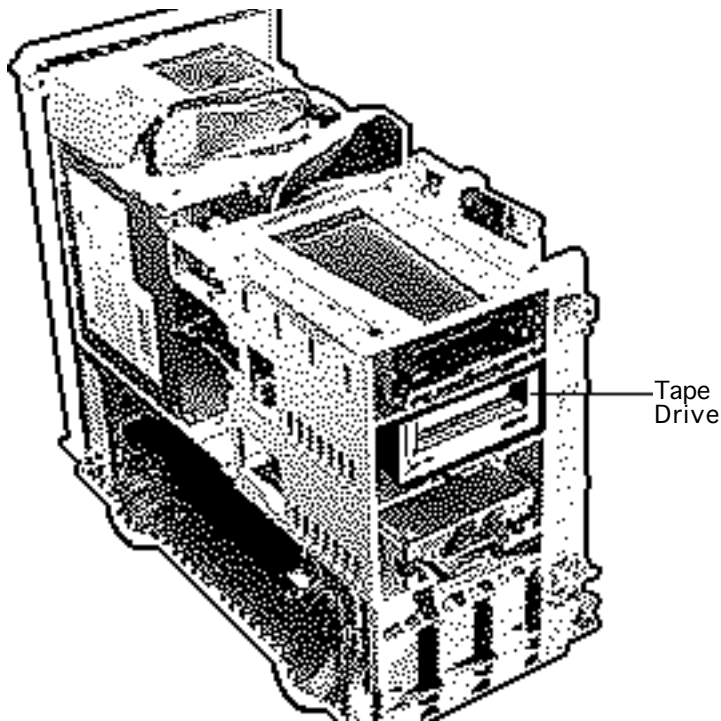

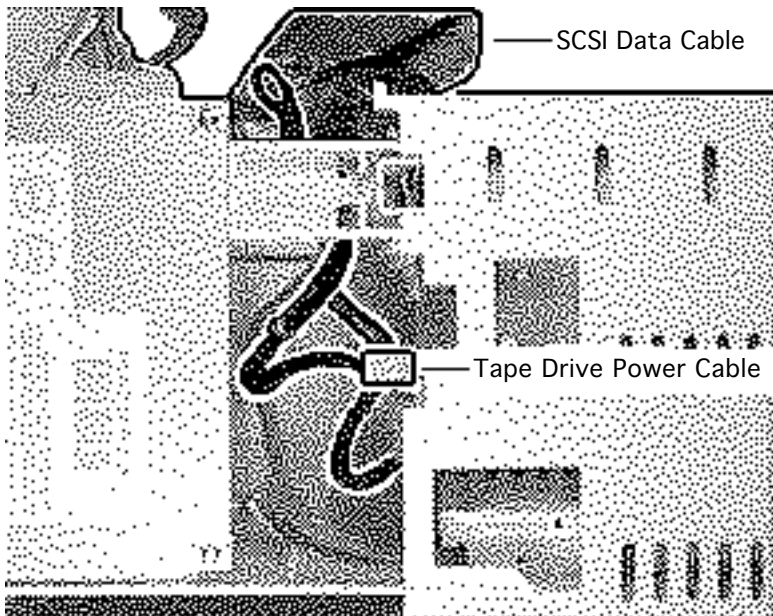

- 1 Disconnect the SCSI data cable and power cable from the back of the tape drive.

**Note:** There are two internal SCSI connectors on the logic board (see “Logic Board Connectors” in Basics for an illustration). In the standard configuration, the SCSI connector at the top of the logic board is used for the CD-ROM/Tape drives, and the SCSI connector near the bottom of the logic board (directly beneath the DRAM and above the reset/



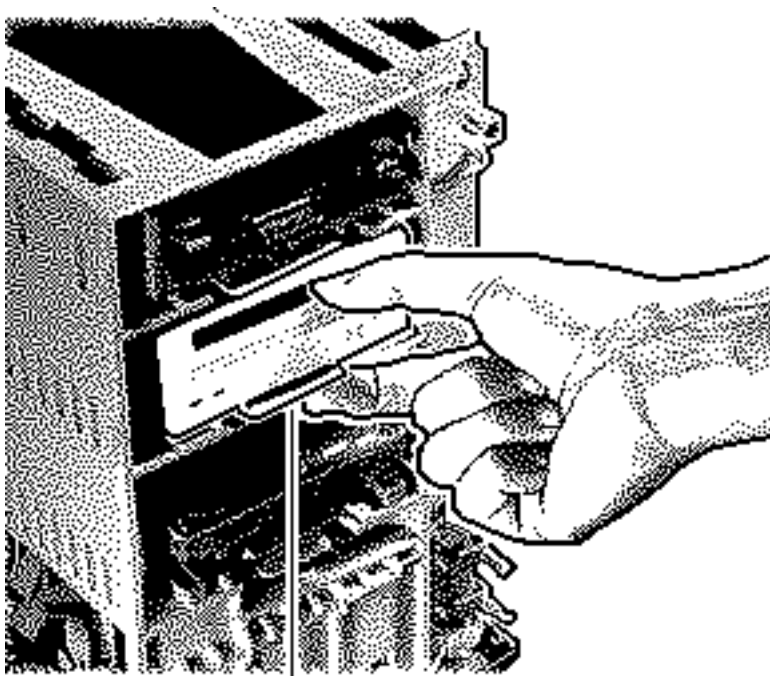

Tape Drive

interrupt switch) is used for the internal hard drive.

- 2 Press down the retaining clip securing the tape drive and slide the tape drive out.

**Replacement Note:** Be sure to remove the tape drive from the carrier prior to returning the drive to Apple.







## Video Card

Before you begin, remove the top housing.

**Caution:** To prevent ESD damage, wear a grounding wriststrap. Review the ESD precautions in Bulletins/ Safety.

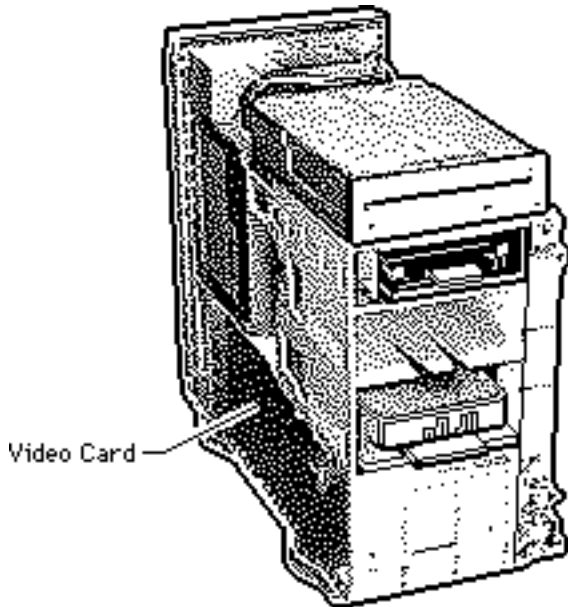

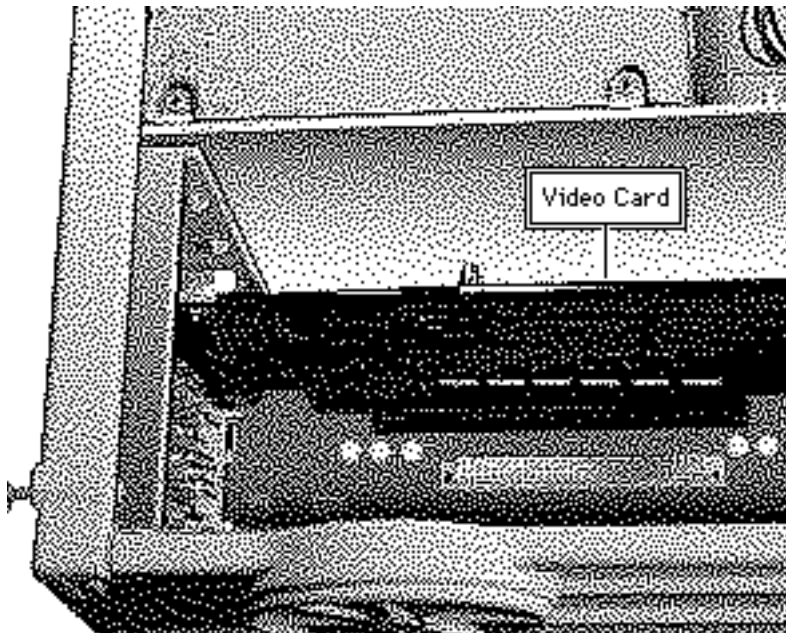

**Note:** All Power Macintosh 8100 series computers require that a video card or PDS termination card be installed in the PDS slot. This procedure describes how to remove either of these cards.



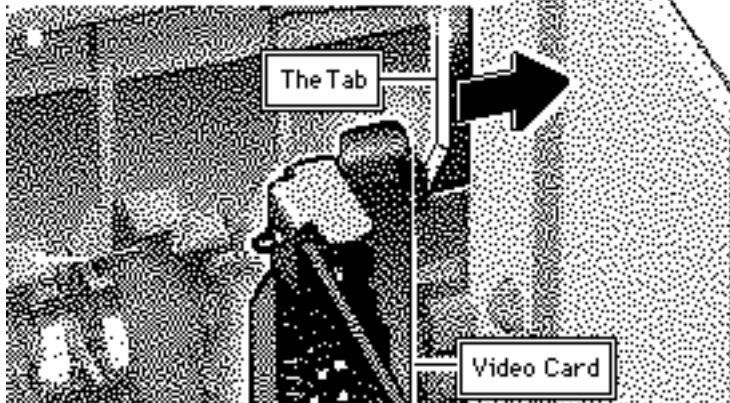
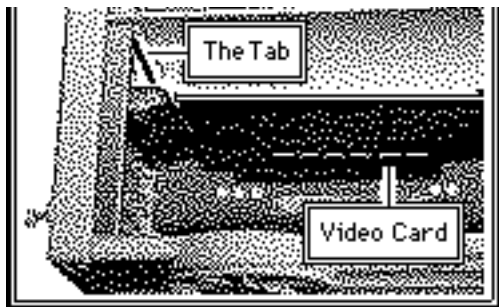

- 1 Push up on the tab that secures the video card to the chassis.



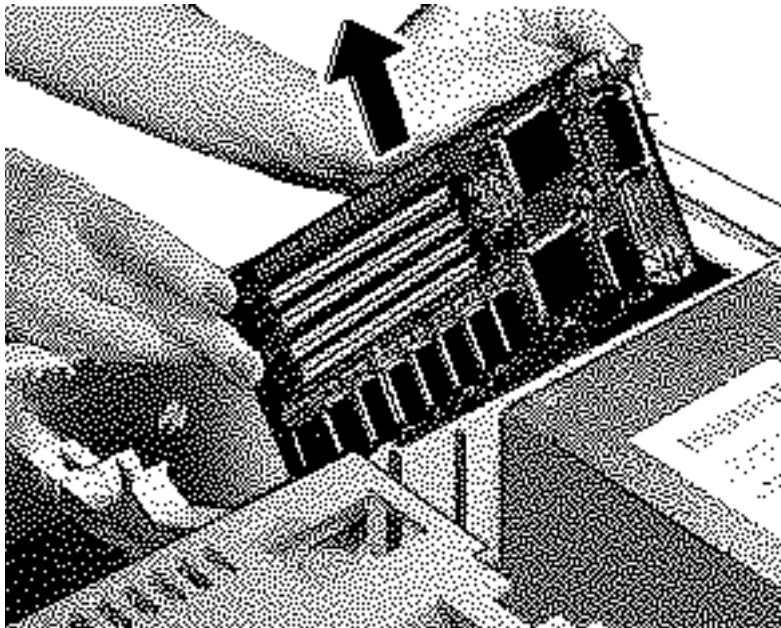

- 2 Gently pull out the video card to remove it.

**Replacement Caution:**

When replacing the card, do not force it into the expansion slot. If the card does not seat properly, remove the card, check the logic board for damage, and try to install the card again.





## Logic Board

Before you begin, remove the following:

- Top housing
- Video card

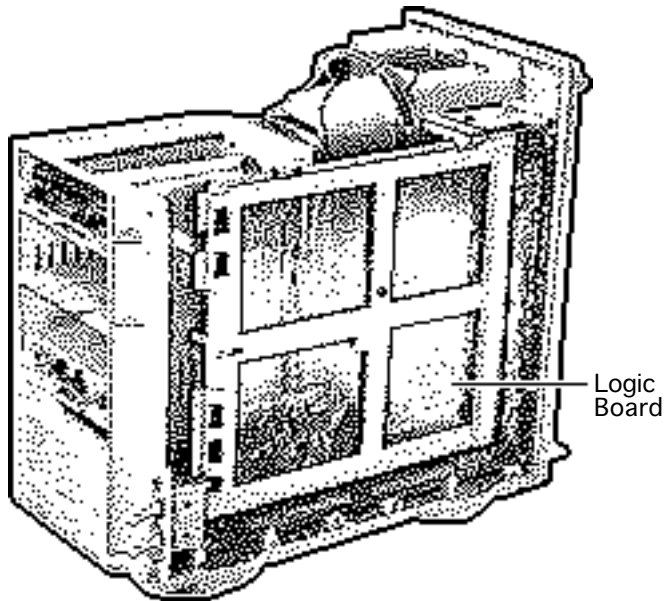



- 1 Disconnect the following cables from the top of the logic board:
  - Logic board power cable
  - Speaker cable
  - LED cable
  - CD-ROM/Tape Drive SCSI cable
  - Floppy drive cable
  - CD-ROM audio cable (if present)
- 2 Disconnect the SCSI hard drive cable from the logic board.

**Replacement Note:** There are two internal SCSI



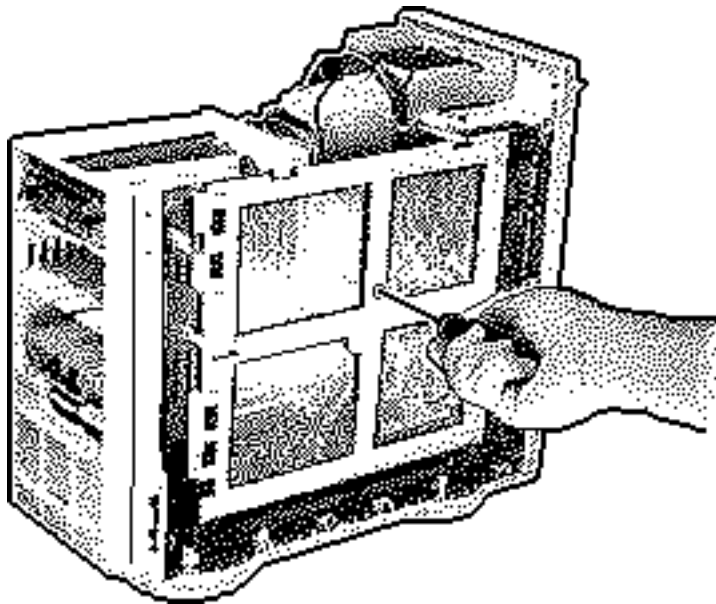

connectors on the logic board (see “Logic Board Connectors” in Basics for an illustration). In the standard configuration, the SCSI connector at the top of the logic board is used for the CD-ROM/Tape drives, and the SCSI connector near the bottom of the logic board (directly beneath the DRAM and above the reset/interrupt switch) is used for the internal hard drive.

- 3 Remove the reset/interrupt actuator.
- 4 Remove the screw



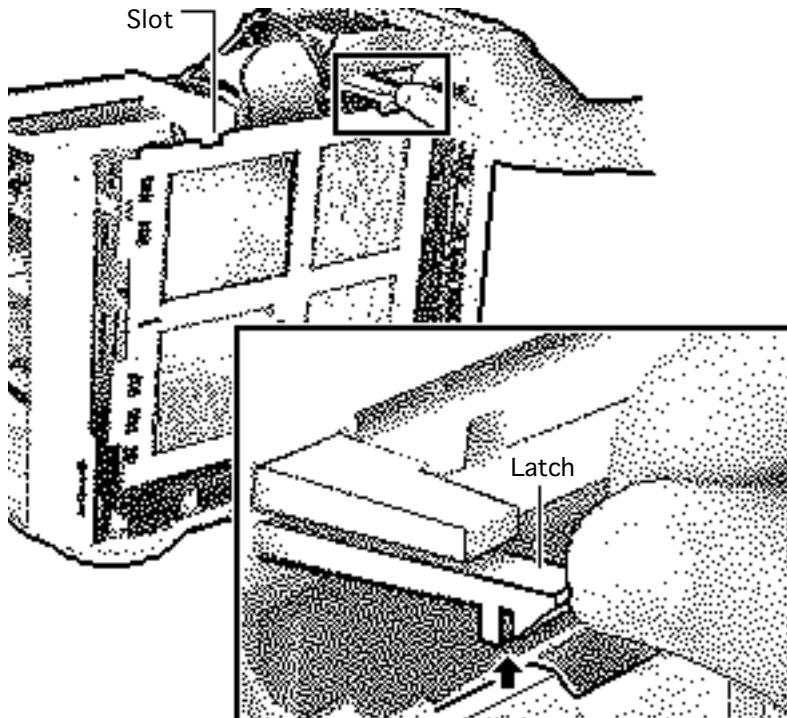

securing the logic board.

**Replacement Note:**

When replacing a Power Mac 8100 series logic board, move the thermoelectric cooling device wires out of the way of the center hole before screwing down the logic board. (See “Logic Board Connectors” in Basics for a description of the thermoelectric cooling device.)

- 5 Slide the logic board forward until the slot lines up with the tab.







- 6 Lift the latch at the rear of the logic board and release the logic board.



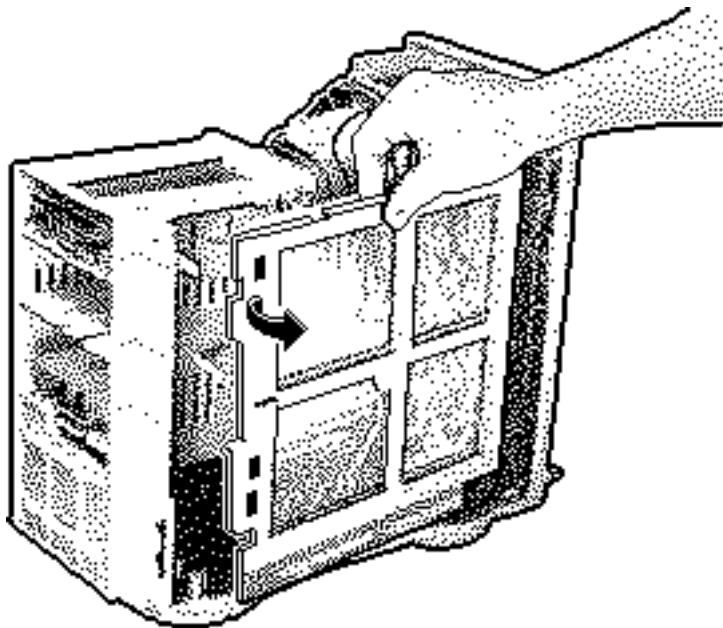

- 7 Pivot the front of the logic board out of the chassis.

**Note:** Remove the 256K cache SIMM and RAM SIMMs before returning the board to Apple, but do **not** remove the ROM SIMM. Refer to the parts database to identify the cache SIMM.

**Note:** Grasp the cache SIMM by its corners and pull up to remove it.

**Replacement Note:** Be sure to reconnect the LED cable to the logic board.





## Power Supply

Before you begin, remove the top housing.

**Caution:** To prevent ESD damage, wear a grounding wriststrap. Review the ESD precautions in Bulletins/ Safety.

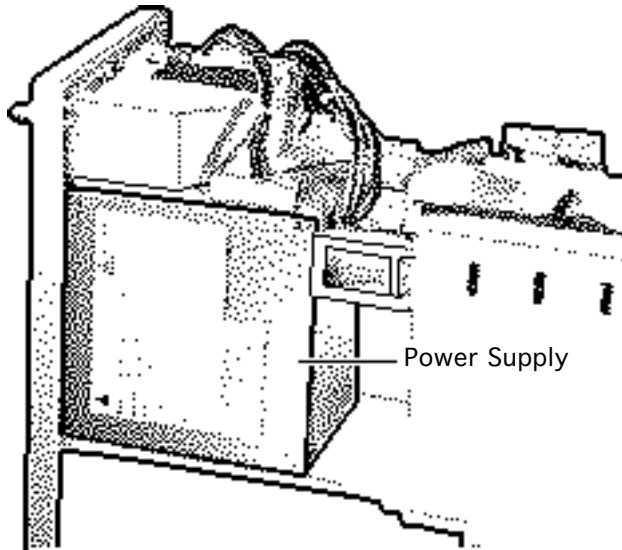



- 1 Remove the chassis support brace.

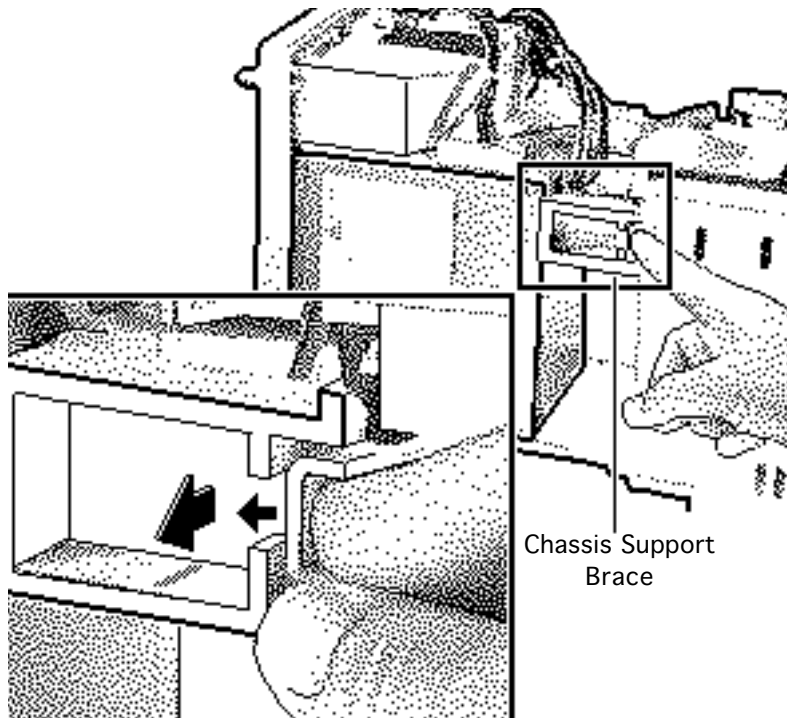

Chassis Support  
Brace





- 2 Disconnect the logic board power cable.

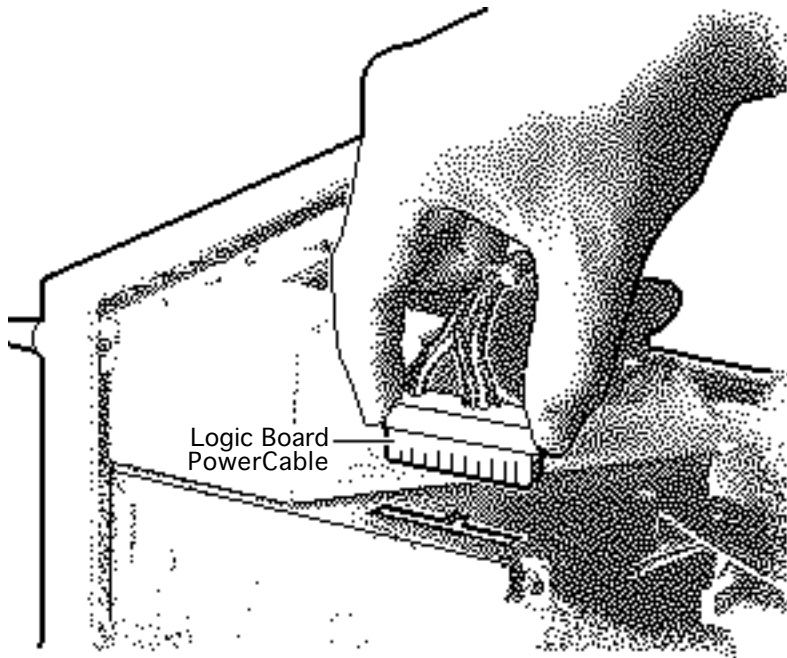

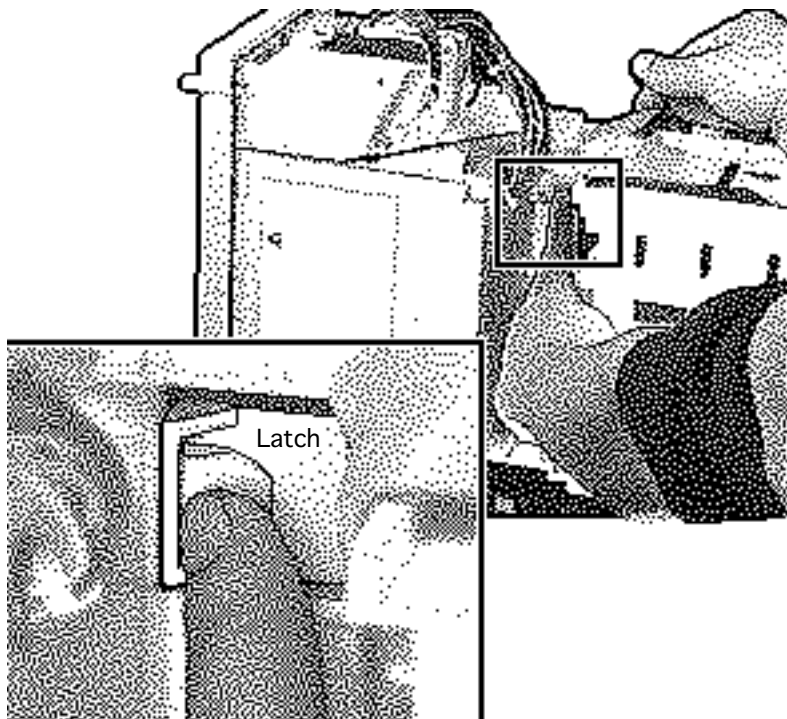

- 3 Press the latch to release the power supply.



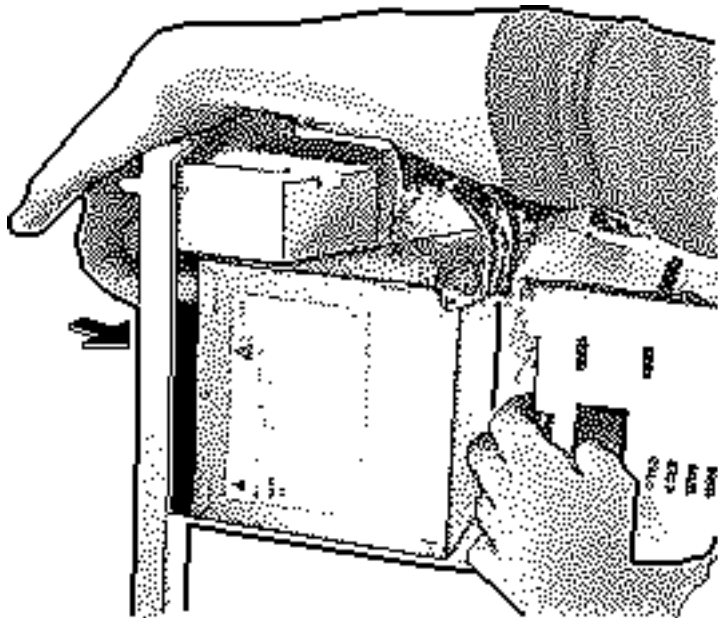

- 4 Slide the power supply forward.
- 5 Pull the power supply out of the computer.





## Speaker

Before you begin, remove the top housing.

**Caution:** To prevent ESD damage, wear a grounding wriststrap. Review the ESD precautions in Bulletins/ Safety.

- 1 Disconnect the speaker cable from the logic board.

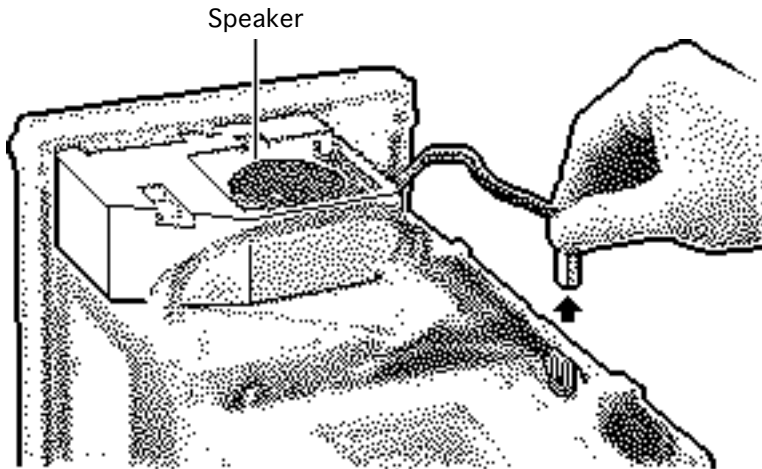



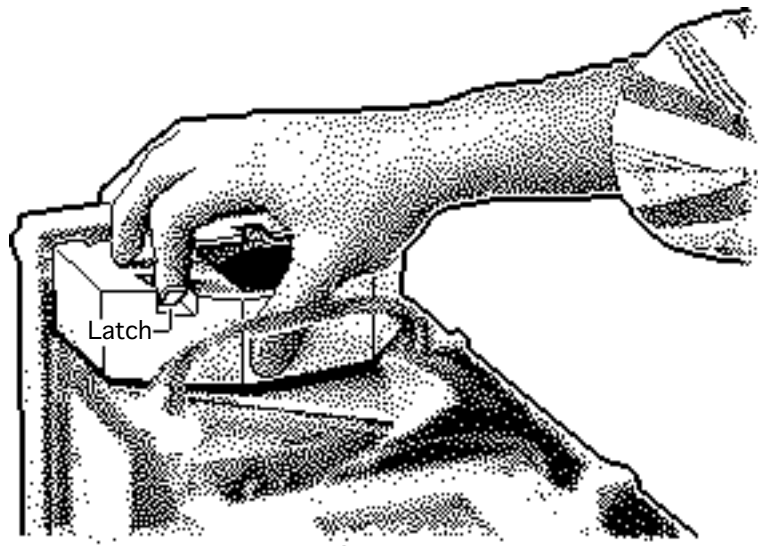

- 2 Press the latch holding the speaker housing to the chassis and lift the front of the speaker housing.
- 3 Pull the speaker housing from the clips at the rear of the chassis.





## Rear Panel

Before you begin, remove the following:

- Top housing
- Speaker

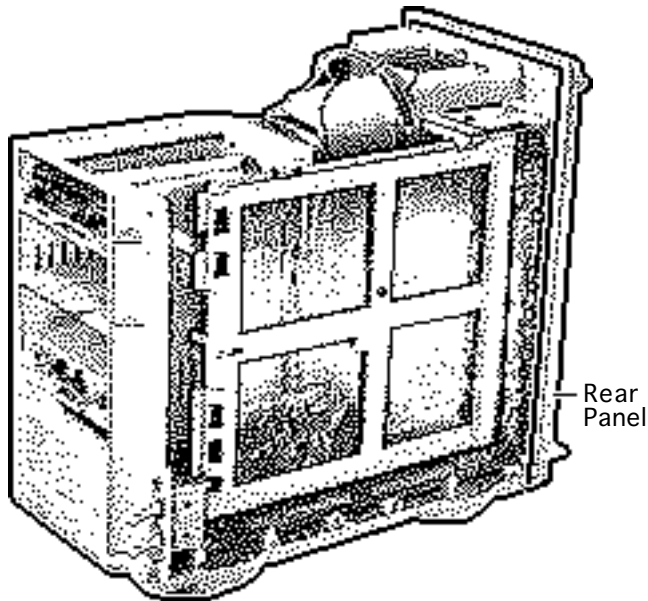

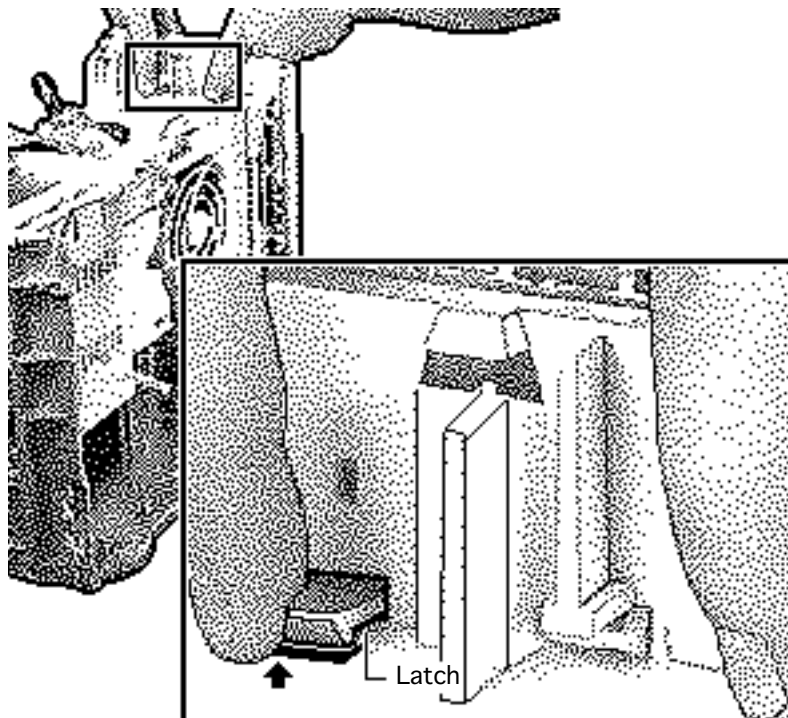

- 1 Lift the two latches and pull the rear panel loose.





- 2 Remove the rear panel from the computer.

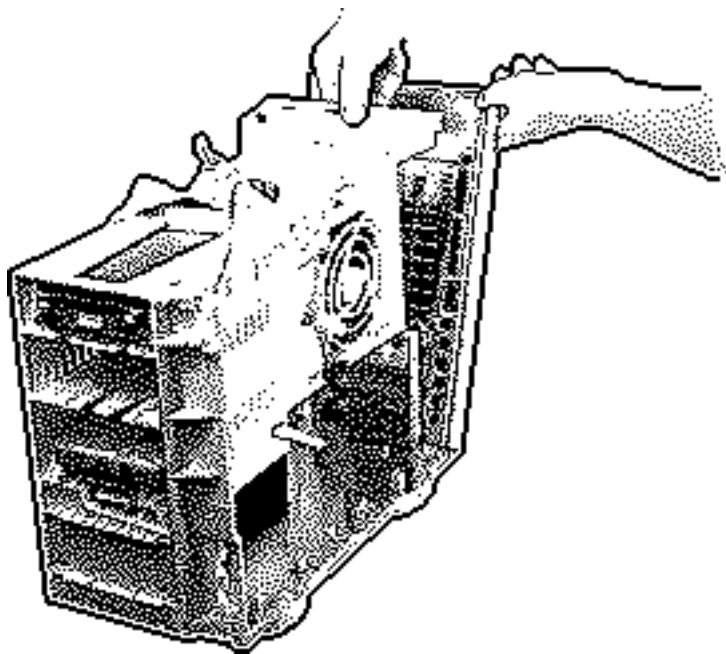



## Additional Procedures

---

Power Macintosh 8100/WS 8150



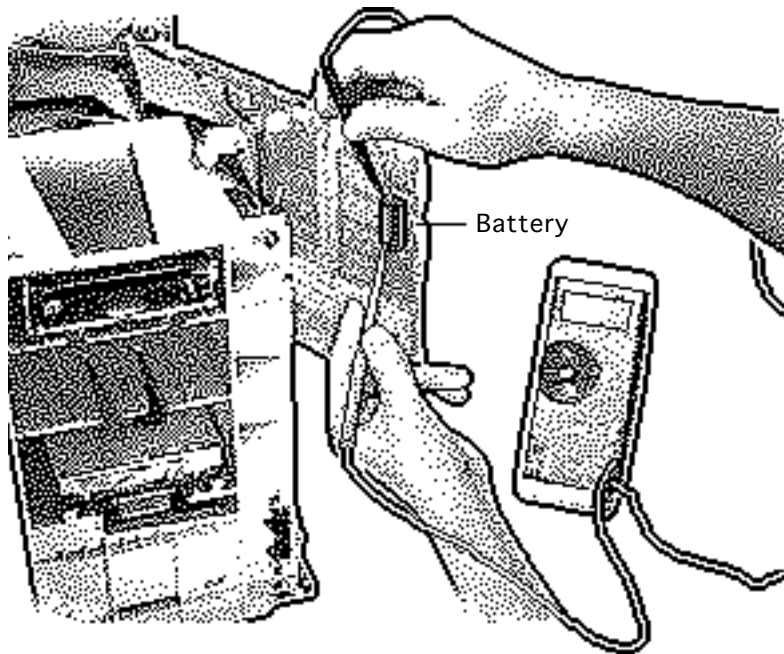

## Battery Verification

Before you begin, remove the following:

- Top housing
- Logic board

**Warning:** If handled or discarded improperly, the lithium battery could explode. Review battery-handling and disposal instructions in Bulletins/Safety.



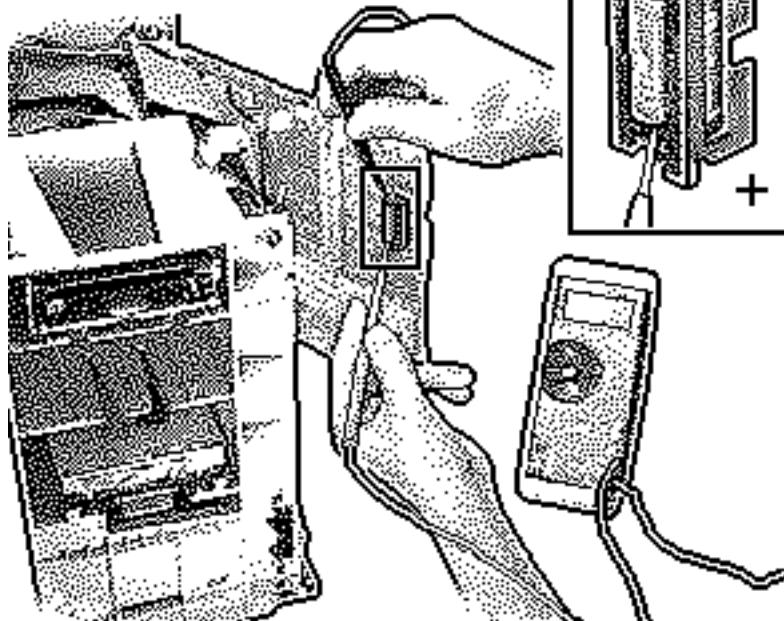

- 1 Set the voltmeter to 10 volts DC scale.
- 2 Hold the positive probe of the voltmeter to the positive end of the battery (“+” on the logic board) and the negative probe to the battery’s negative end.
- 3 If the battery voltage is below 3.2 volts, replace the battery. Refer to “Battery Replacement.”





**Note:** Make sure the battery is installed in the correct +/- direction.







## Battery Replacement

Before you begin, remove the following:

- Top housing
- Logic board

**Warning:** If handled or discarded improperly, the lithium battery could explode. Review battery-handling and disposal instructions in Bulletins/ Safety.

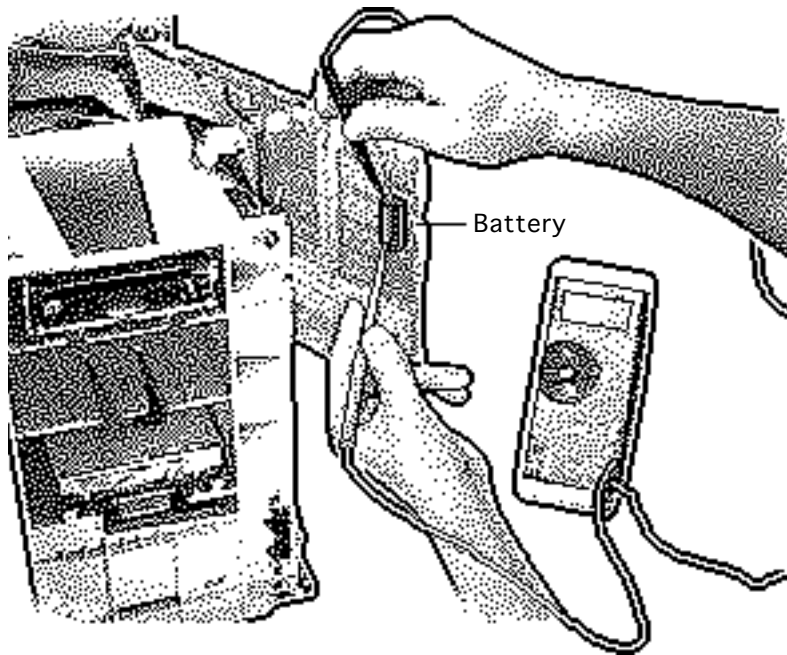

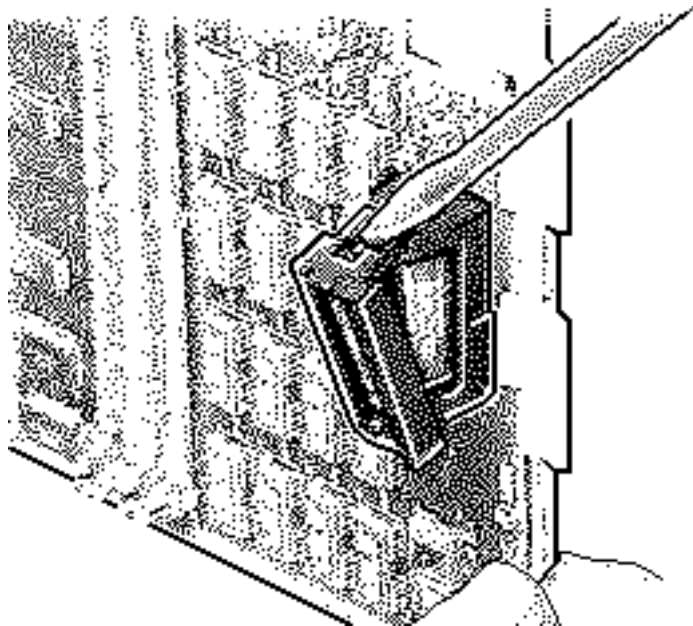

- 1 Using a small flat-blade screwdriver, pry open the latch at the end of the battery holder and lift off the cover.



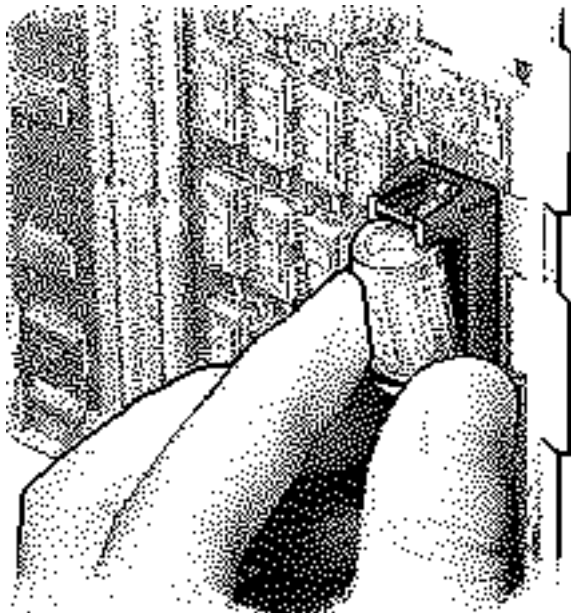

- 2 Grasp the battery and remove it from the holder.
- 3 Return the battery to Apple for proper disposal. For battery packaging and labeling instructions, refer to the safety information in Bulletins/Safety.

**Note:** Make sure the battery is installed in the correct +/- direction.





## Reset Logic Board

Before you begin, remove the following:

- Top housing
- Power cord
- Logic board

**Note:** Whenever you have a unit that fails to power up, you should follow this procedure to reset the logic board **before** replacing any modules.

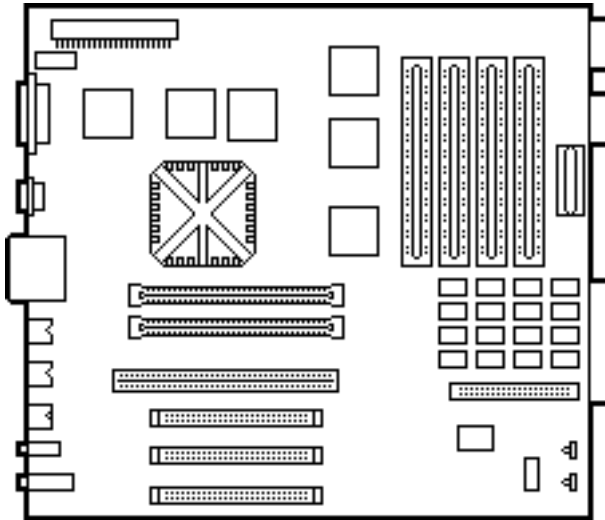

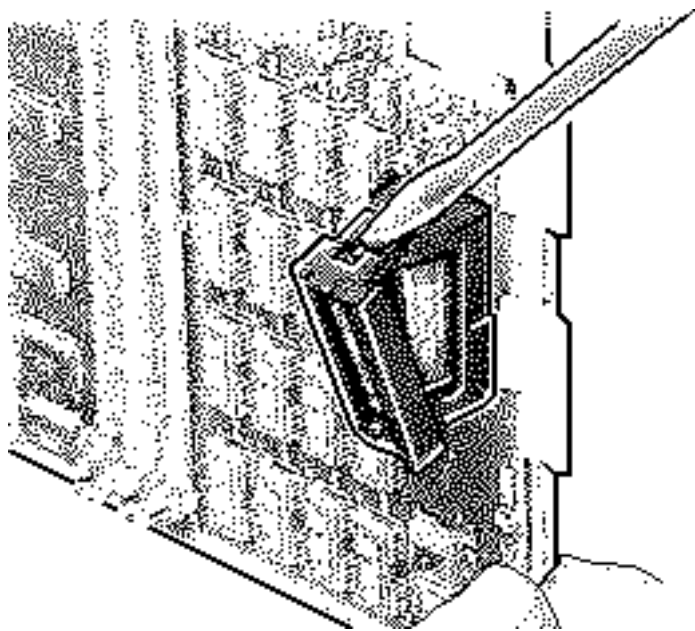

**Warning:** If handled or discarded improperly, the lithium battery could explode. Review battery-handling and disposal instructions in Bulletins/Safety.

- 1 Unplug the computer first.
- 2 Using a small flat-blade screwdriver, pry open the latch at the end of the battery holder and lift off the cover.





- 3 Grasp the battery and remove it from the holder.

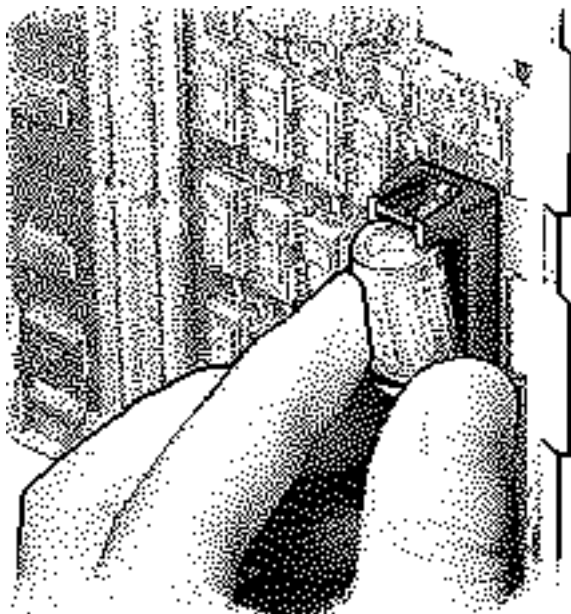

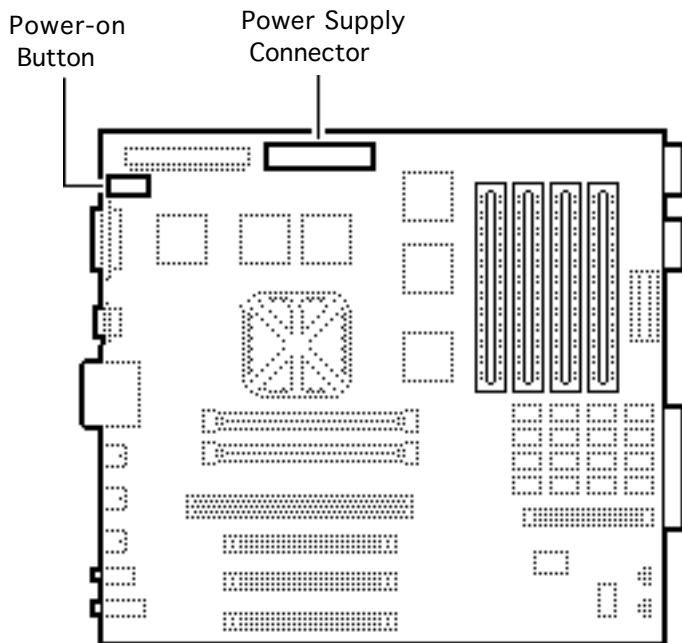

- 4 Press the computer's power-on button. Verify that the power supply cable is disconnected from the logic board. Wait 5-10 minutes and then:
  - Replace battery
  - Reassemble computer

**Note:** Make sure the battery is installed in the correct +/- direction.

**Note:** This procedure resets PRAM. Be sure to check the computer's time/date and other PRAM settings.





**Note:** If this procedure resolves the problem, claim an adjustment on an SRO. If not, replace the defective component and **do not** claim the adjustment procedure.







## Upgrades

---

Power Macintosh 8100/WS 8150





## Expansion Cards

Before you begin, remove the top housing.

**Caution:** To prevent ESD damage to components, wear a grounding wriststrap. Review the ESD precautions in Bulletins/Safety.

- 1 Pinch the two handles and remove the NuBus card retainer.

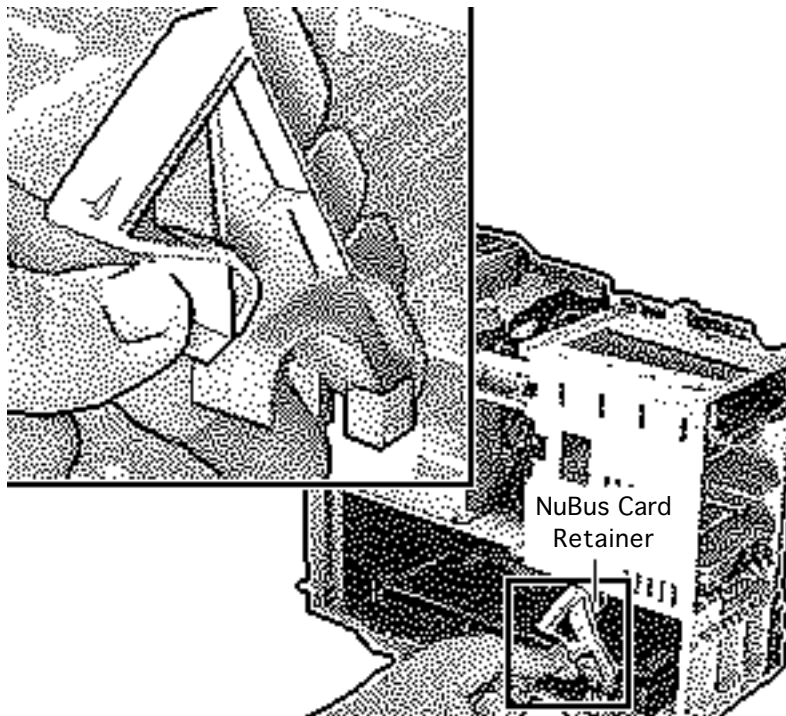

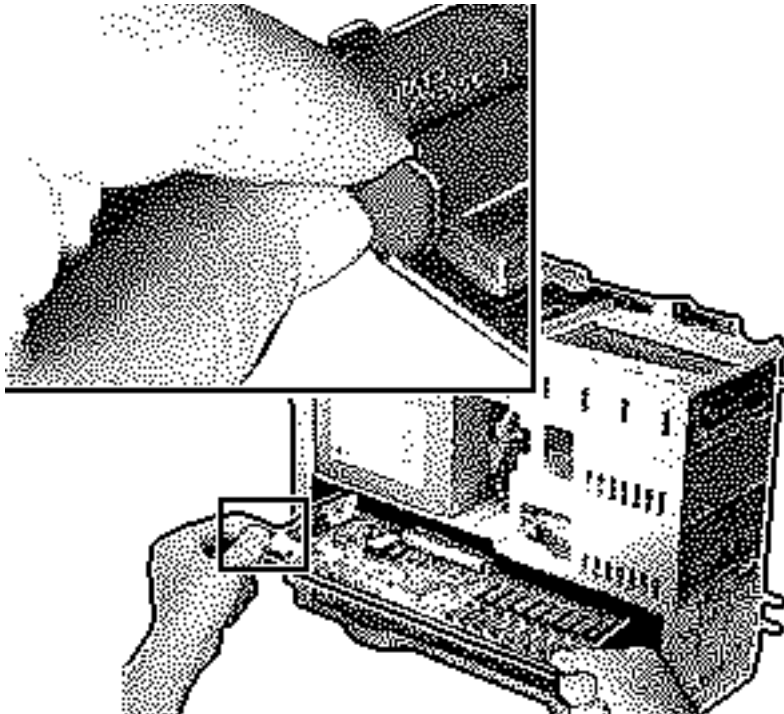

- 2 **Caution:** Pull up evenly on both sides of the card to avoid bending the connector pins.

Carefully grasp each end of the card and pull straight out to remove it.

**Note:** Grab the left side of the card by the metal bracket.

**Replacement Caution:** Do not force the card into the expansion slot. If the card does not seat properly, remove it and try again.





Upper Blank Bezel

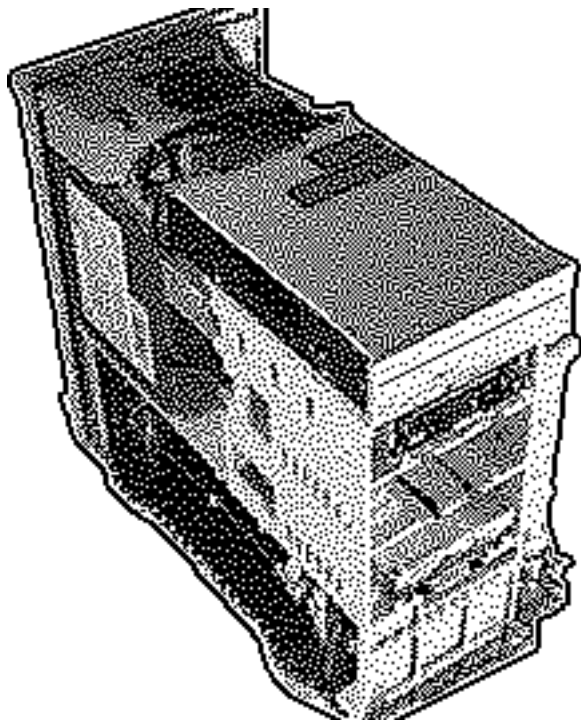

## CD-ROM Upgrade

Before you begin, remove the top housing.

**Caution:** To prevent ESD damage to components, wear a grounding wriststrap. Review the ESD precautions in Bulletins/Safety.





Upper Blank Bezel

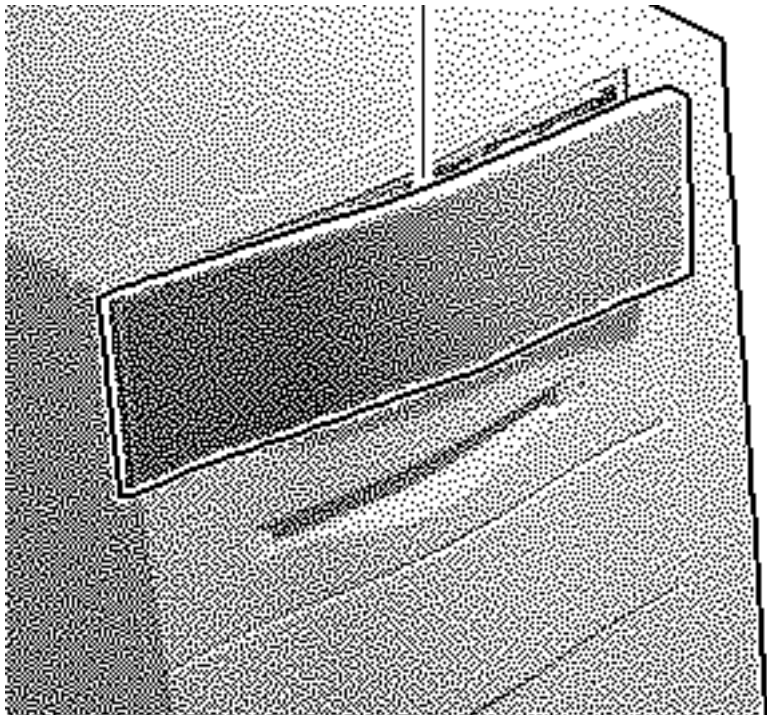

- 1 Remove the upper blank bezel from the top housing.





CD-ROM Drive Bezel

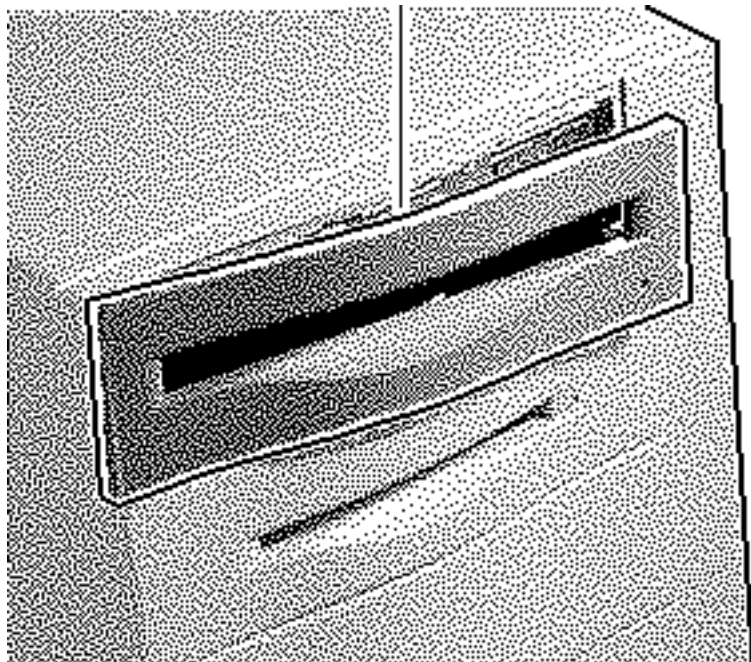

- 2 Install the slotted CD-ROM drive bezel in the top housing.



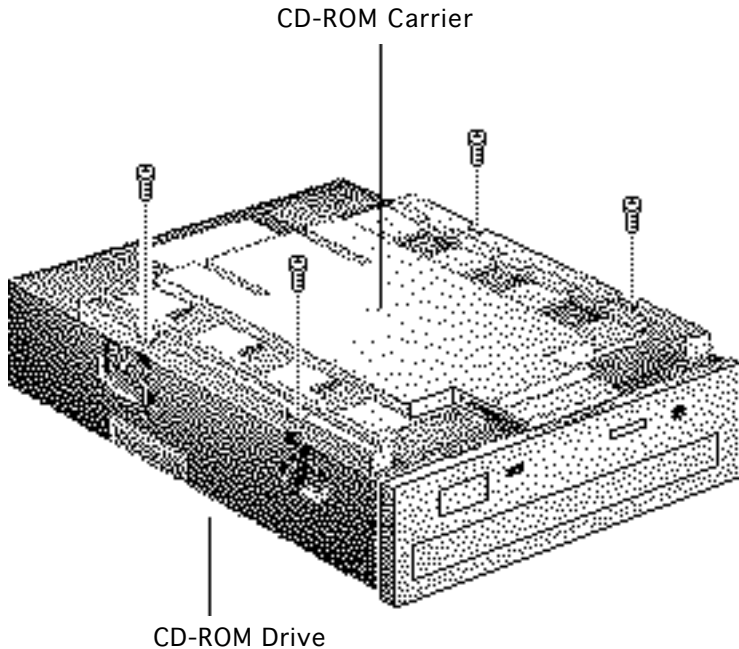

- 3 Attach the CD-ROM carrier to the CD-ROM drive with four Phillips screws.





- 4 Verify that the three jumper connectors are installed as shown.

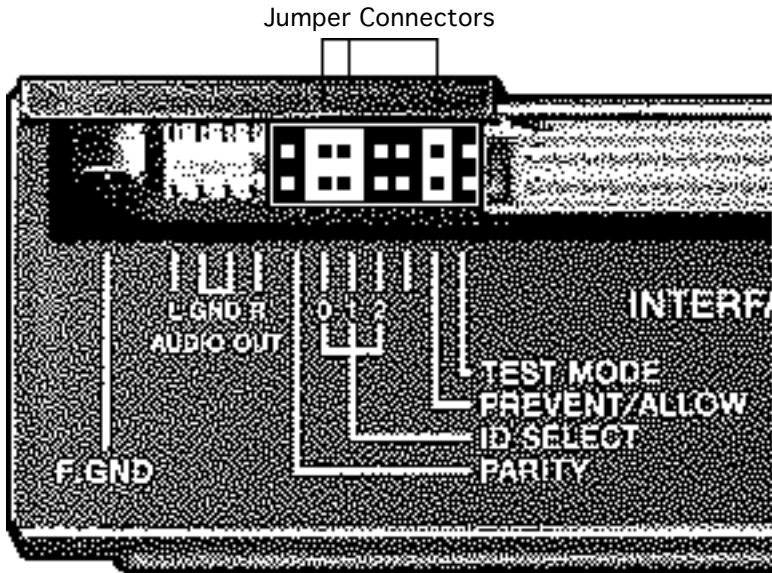

**Important:** These jumpers configure the SCSI device address of the CD-ROM drive. The CD-ROM drive will have a SCSI device ID of 3. Verify that no other SCSI device installed in the computer already has that address. If another device does have an ID of 3, change the ID prior to installing the CD-ROM drive.





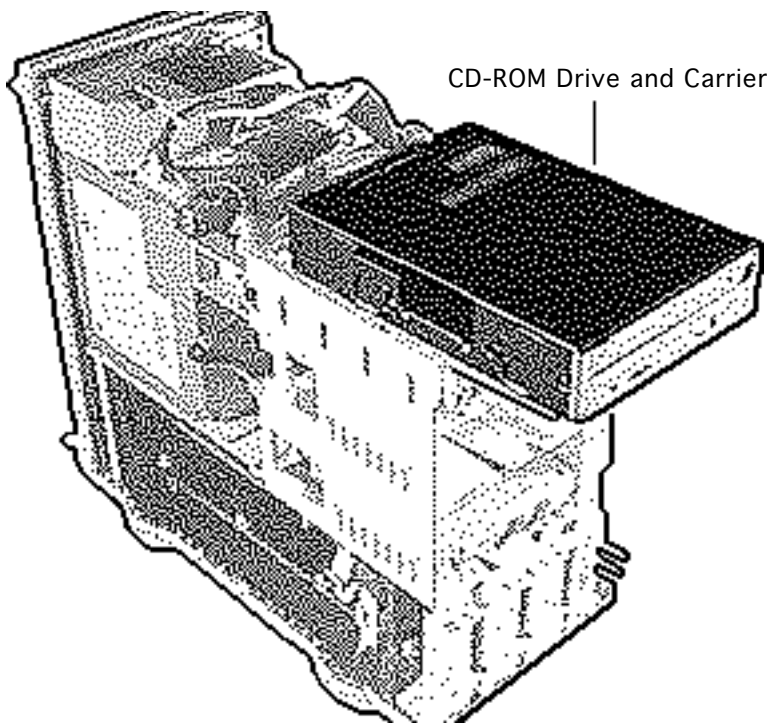

- 5 Slide in the CD-ROM drive and carrier.



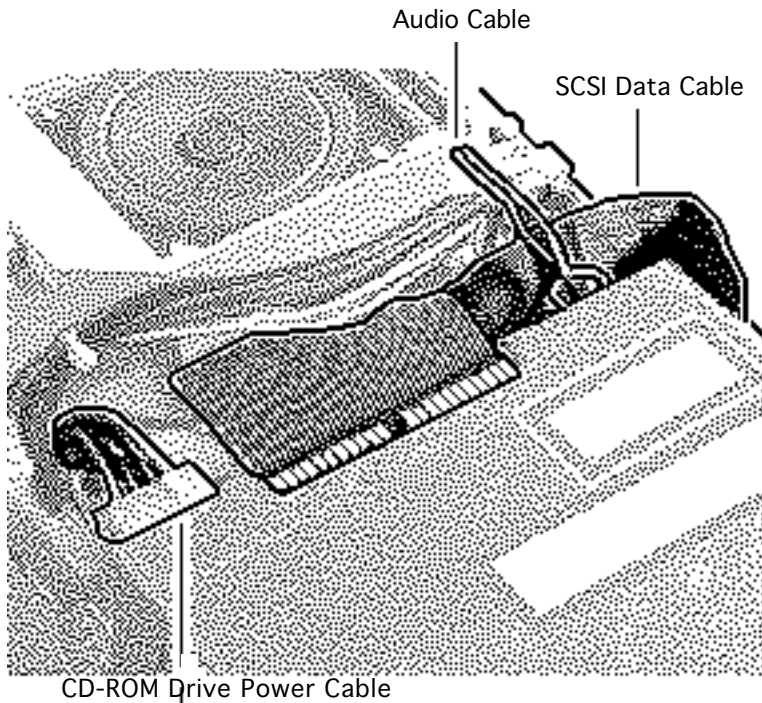

- 6 Connect these cables to the CD-ROM drive:
- Audio cable
  - SCSI data cable
  - CD-ROM drive power cable





## Power Macintosh Upgrade

Before you begin, remove

- Top housing
- Top housing bezels
- Floppy drive
- Hard drive
- CD-ROM drive (if present)
- Logic board
- Power supply
- Speaker

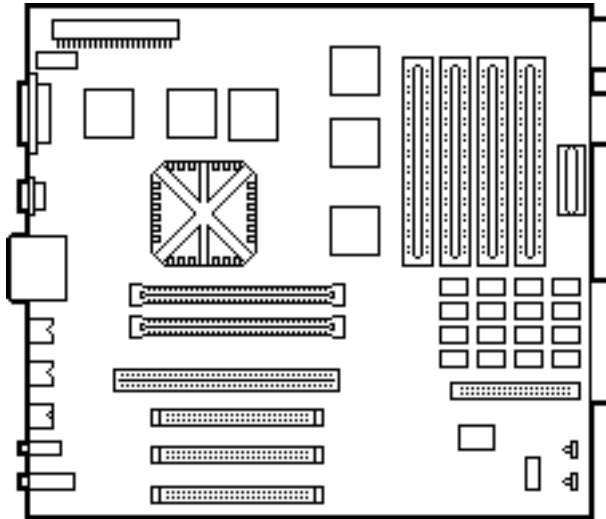

Power Macintosh 8100 Series  
and WS 8150 Logic Board

**Note:** The Power Macintosh 8100/80 logic board upgrades a Quadra 800 or 840AV. The WS 8150 logic



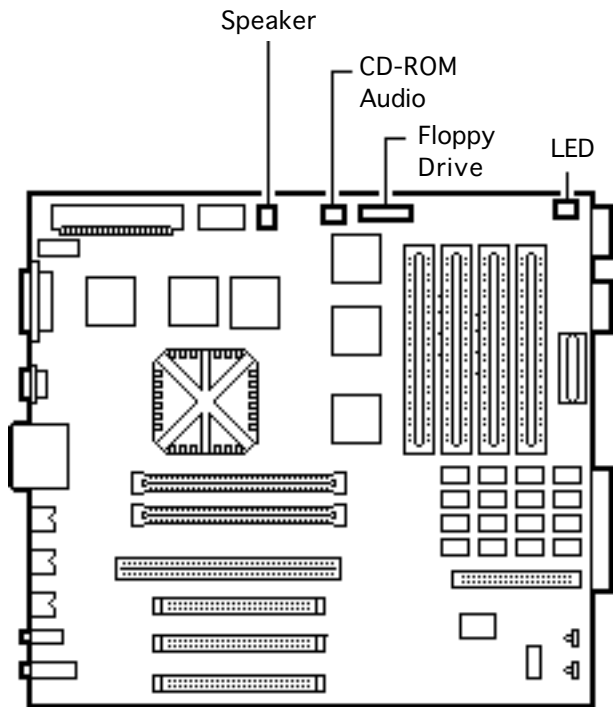

board upgrades an AWS 80.

**Note:** The upgrade kit contains a logic board, internal chassis, top housing, CD-ROM and hard drive SCSI cables, SCSI power cable, reset/interrupt actuator, and video card.

- 1 Remove the following cables from the old logic board and connect them to the new logic board:
  - LED cable
  - Speaker cable
  - CD-ROM audio cable
  - Floppy drive cable



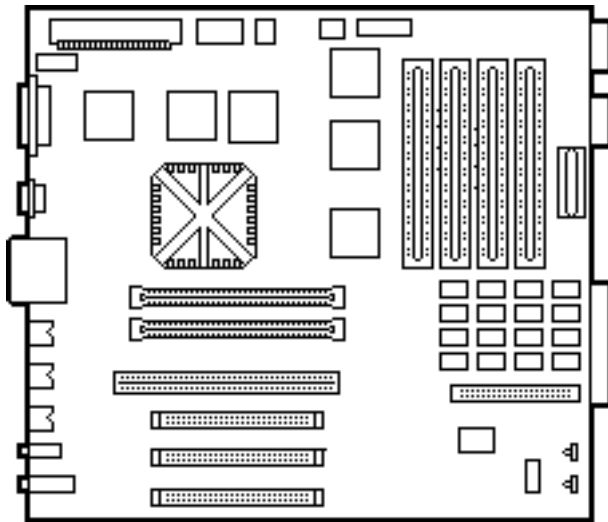

- 2 Install the speaker in the upgraded chassis.
- 3 If the customer's original logic board had DRAM SIMMs installed, remove them and install them on the upgraded logic board.

**Important:** Upgraded units require that DRAM SIMMs be installed in matching pairs (i.e., same size and speed). The SIMMs must be 80 ns or faster, non-composite, 72-pin SIMMs.



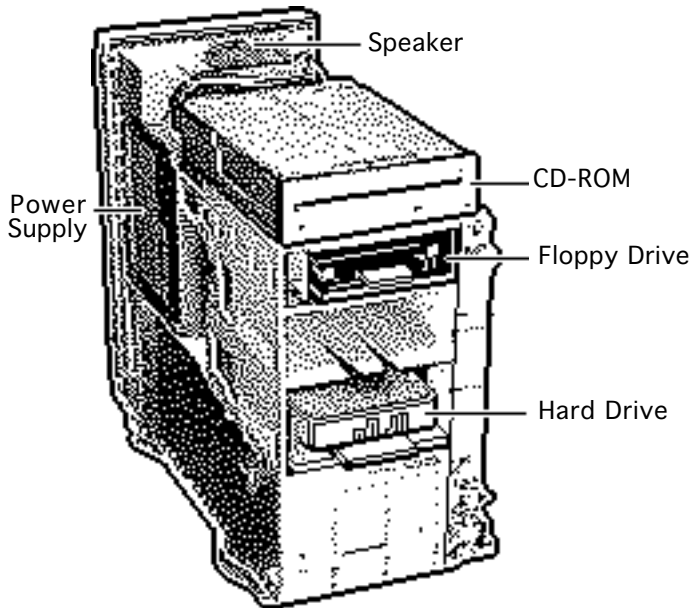

**Replacement Note:** Return all VRAM and non-matching DRAM SIMMs from the old logic board to the customer.

- 4 Remove the existing power cable from the power supply and the SCSI cables from the hard drive and CD-ROM drive.
- 5 Install the floppy drive, hard drive, CD-ROM drive (if present), power supply, and speaker in the upgraded internal chassis.





**Note:** The upgrade kits ship with new SCSI cables and a new power cable attached to the logic board. The equivalent cables in the original unit are **not** forward compatible. You must use the new SCSI and power cables provided in the kit.

**Replacement Note:** The top SCSI cable connects to the CD-ROM unit. The bottom SCSI cable connects to the hard drive.

**Note:** These upgraded units **must** have a video card installed for proper bus termination. The 8100/80 requires the Power Macintosh 4 MB Video Card; the 8100/80AV requires the Power Macintosh AV Card. The WS 8150 requires a video terminator card.



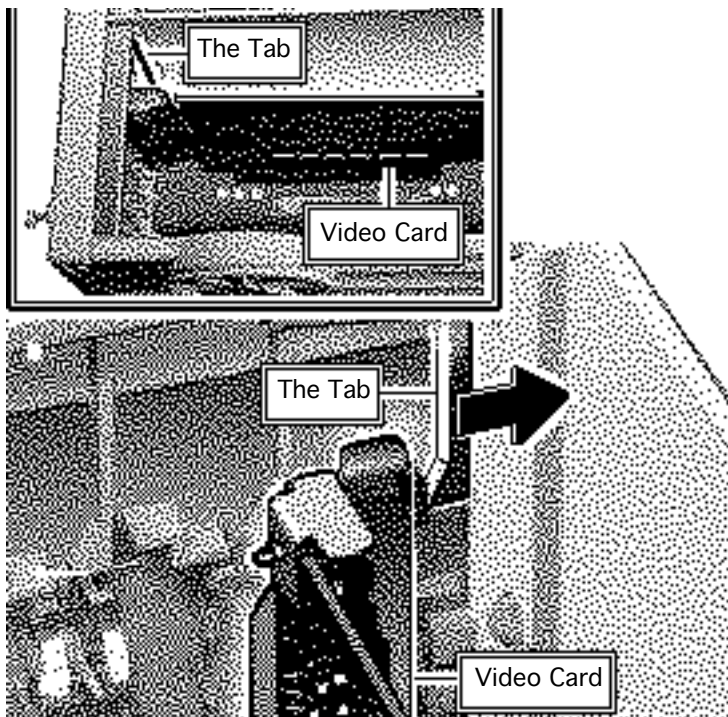

**Caution:** Install the video card at an angle, inserting the back end (the non-connector end) first. Do not force the card into the expansion slot. If the card does not seat properly, remove the card, check the logic board for damage, and try to install the card again.

- 6 Gently push down on the video card until it snaps into place.

**Replacement Note:** Push up on the tab that holds the video card in place to remove the card.







CD-ROM Bezel



Floppy Drive Bezel

- 7 Remove the bezels from the old top housing and install them on the new top housing.
- 8 Copy the computer's serial number from the old top housing to the new top housing.

**Note:** A blank serial number label is provided on the new top housing.



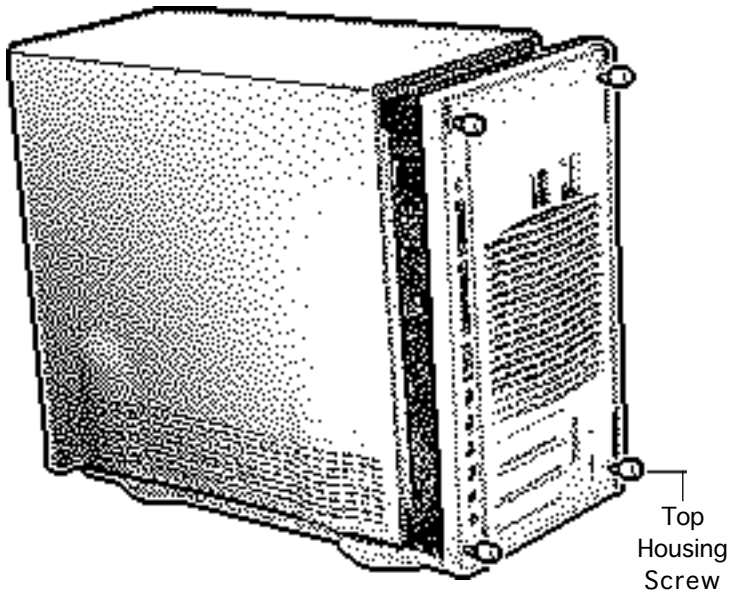

- 9 Move the top housing screws from the old unit to the new unit and reassemble the computer.

**Note:** For the Power Macintosh 8100/80 and 8100/80AV upgrades, you must install the System 7.1.2 software that came with the upgrade kit. Refer to the user manual provided in the upgrade kit for installation instructions.





10 Run MacTest Pro in looping mode or other software in demo mode for 1 hour as a burn-in test.

**Note:** Contact Finished Goods for an RMA number to return the old logic board. Return the logic board in the old housing. You do not need to return the cables to Apple.





## Power Macintosh 8500 Upgrade

The Power Macintosh 8500 Upgrade Kit can be used to upgrade a Quadra 800, Quadra 840, or a Power Macintosh 8100. The kit includes everything except:

- The peripherals (such as the hard drive, floppy drive, and CD-ROM drive), which must be transferred from the original unit you are upgrading
- A processor card, which must be purchased separately.

Refer to the appropriate Take Apart chapter (that is, the Take Apart chapter in the Quadra 800, Quadra 840AV, or Power Macintosh 8100 manual) for instructions on how to remove the drives from the original unit.

Refer to the Take Apart chapter in the Power Macintosh 8500/WS 8550 manual to see where the peripherals should be installed in the upgraded unit and for instructions on how





to install the processor card.

Once you have installed all the drives in the upgraded unit and replaced the top housing, copy the serial number from the original unit to the blank serial label on the upgraded unit.





## WorkGroup Server 8550/132 Upgrade

The WorkGroup Server 8550/132 Upgrade Kit can be used to upgrade a WorkGroup Server 80, 8150/80, or 8150/110. The kit includes everything except:

- The peripherals (such as the hard drive, floppy drive, and CD-ROM drive), which must be transferred from the original unit you are upgrading
- Drive carriers
- Drive bezels
- Drive shields
- Speaker
- CD-ROM audio cable
- Floppy drive cable
- Power supply to logic board cable
- Chassis support bracket
- DRAM DIMMs





All of the part listed above, except for the DRAM DIMMs, need to be removed from the original unit and installed in the upgraded unit. Refer to the Take Apart chapter for the product from which you are upgrading for instructions on how to remove these parts. Refer to the Take Apart chapter in the Power Macintosh 8500/WS 8550 manual to see where the peripherals should be installed in the upgraded unit.

**Note:** The WS 8550 logic board in the upgrade kit does not contain any DRAM. You must install 64 bit-wide, 168-pin DRAM DIMMs. The DIMMs should be fast-paged mode, 70 ns or faster. You can use 8, 16, 32, or 64 MB DIMMs, which can be installed in any configuration. For the best performance, however, the DIMMs should be installed in pairs of the same size into paired slots. The slower 80 ns SIMMs and DIMMs used in older Macintosh computers will not work reliably in the WS 8550.





Once you have installed all the necessary parts in the upgraded unit and replaced the top housing, copy the serial number from the original unit to the blank serial label on the upgraded unit.

**Note:** The WorkGroup Server 8550/132 Upgrade Kit does not include a hard drive bracket.







Exploded View

---

Power Macintosh 8100/WS 8150



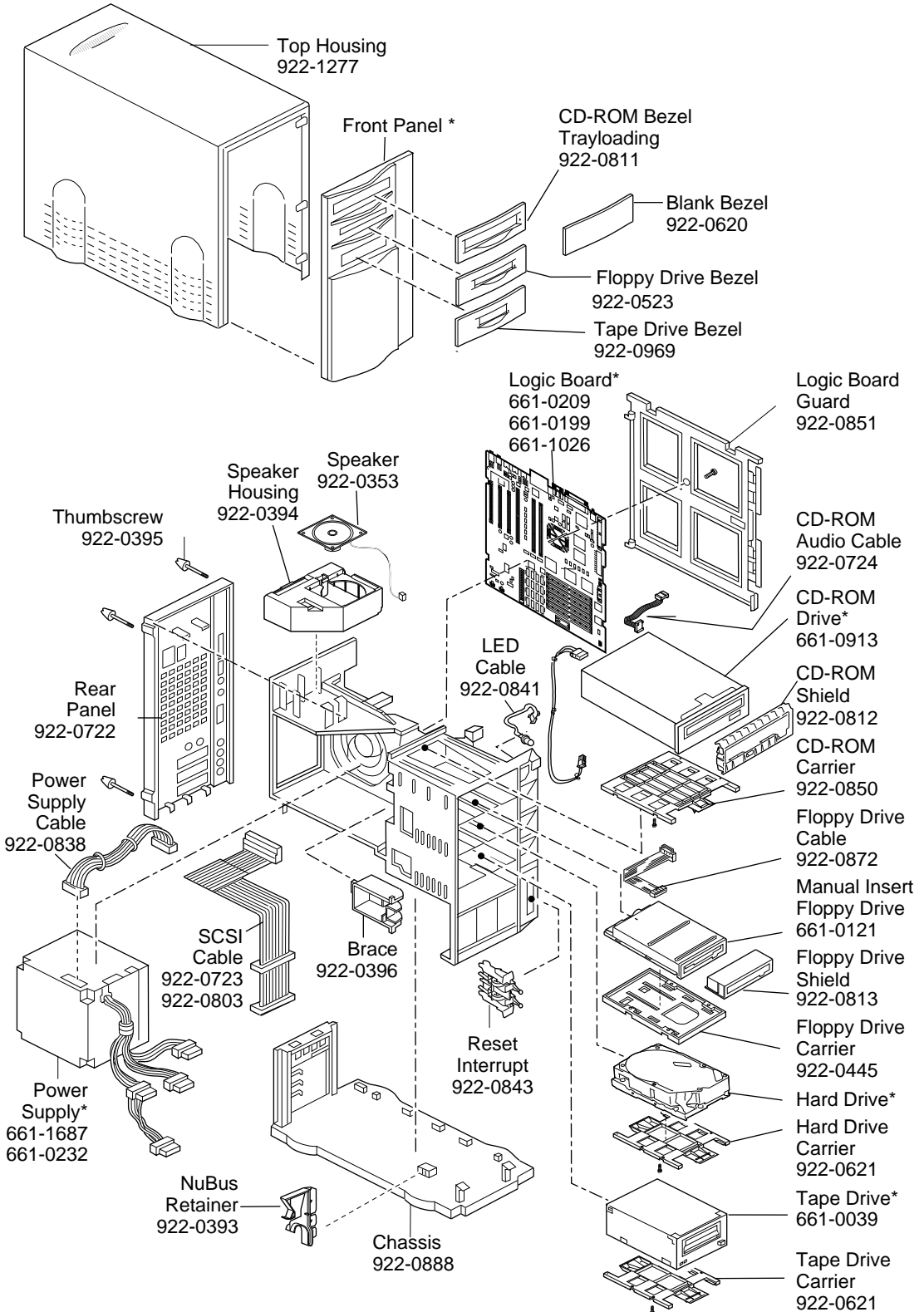

Product family configurations may vary. For parts with asterisk (\*), refer to parts list.

**Power Macintosh 8100/WS8150**

